

20V, 1.25A Low Dropout Voltage Linear Regulator

Features

- Output voltage accuracy : +/- 2%
- Low Dropout Voltage:1.15V at 1.25A Output Current
- Input Voltage Range: Max 20V
- Trimmed Current Limit
- On-Chip Thermal Shutdown
- Three-terminal Adjustable or Fixed 1.2V, 1.5V, 1.8V, 2.5V, 2.85V, 3.3V, 5.0V
- Operation Temperature Range: -40'C to 125'C
- SOT-89-3 and SOT-223 Packages Available

Applications

- PC Motherboard
- Graphic Card
- LCD Monitor and LCD TV
- DVD-video Player
- Telecom Equipement
- ADSL Modem
- Printer and other Peripheral Equipment.

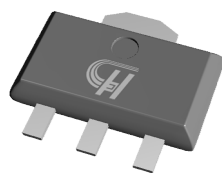
General Description

The HCR1117H is a series of low dropout three-terminal regulators with a dropout of 1.15V at 1.25A load current .

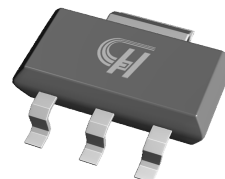
The HCR1117H series provides current limiting and thermal shutdown. Its circuit includes a trimmed bandgap reference to assure output voltage accuracy to be with 1% for 1.5V, 1.8V, 2.5V, 2.85V, 3.3V, 5.0V and adjustable voltages versions or 2% for 1.2V version. Current limit is trimmed to ensure specified output current and controlled short-circuit current. On-chip thermal shut-down provides protection against any combination of overload and ambient temperature that would create excessive junction temperature.

The HCR1117H has an adjustable version, that can provide the output voltage from 1.25V to 12V with only 2 external resistors.

The HCR1117H series is available in the industry standard SOT-89-3 and SOT-223 power packages.

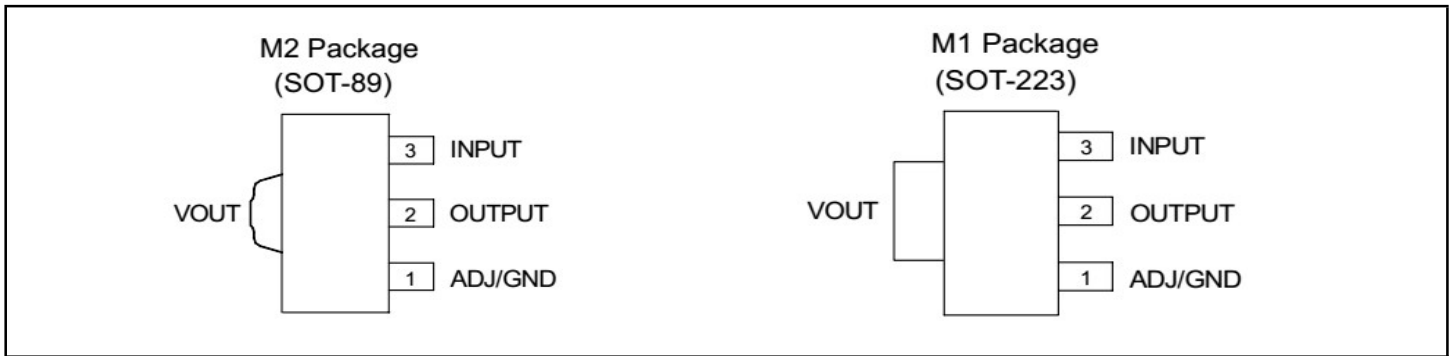


SOT-89-3

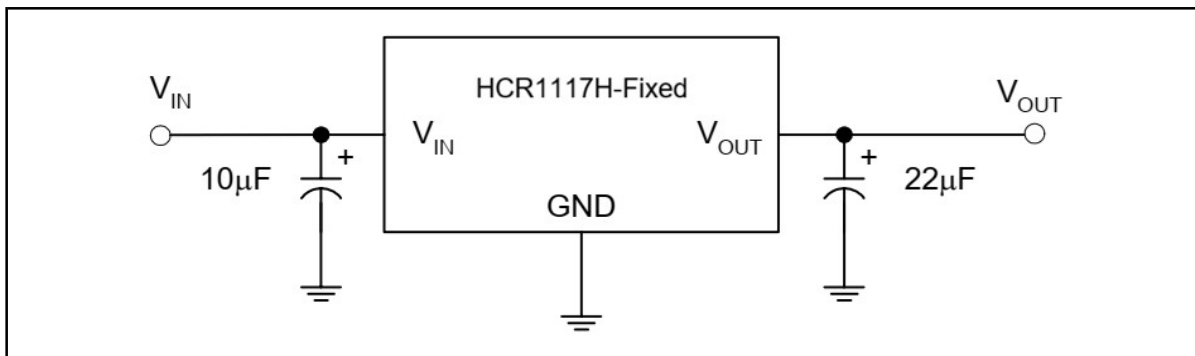
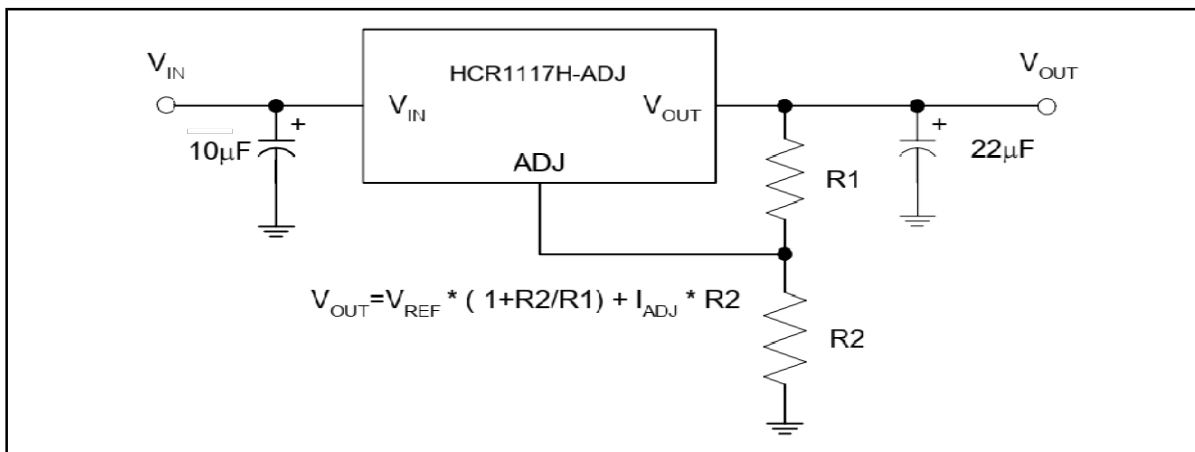


SOT-223

Figure 1. Package Type of HCR1117H

20V, 1.25A Low Dropout Voltage Linear Regulator
Pin Configuration

Figure 2. Pin Configuration of HCR1117H (Top View)
Pin Description

SOT-89-3 (Package: M2)	SOT-223 (Package: M1)	Pin Name	Pin Function
3	3	INPUT	Input Voltage
2	2	OUTPUT	Output Voltage
1	1	ADJ/GND	ADJ / GND

Typical Applications

Figure 3. Fixed output Voltage of HCR1117H

Figure 4. Adjustable output Voltage of HCR1117H

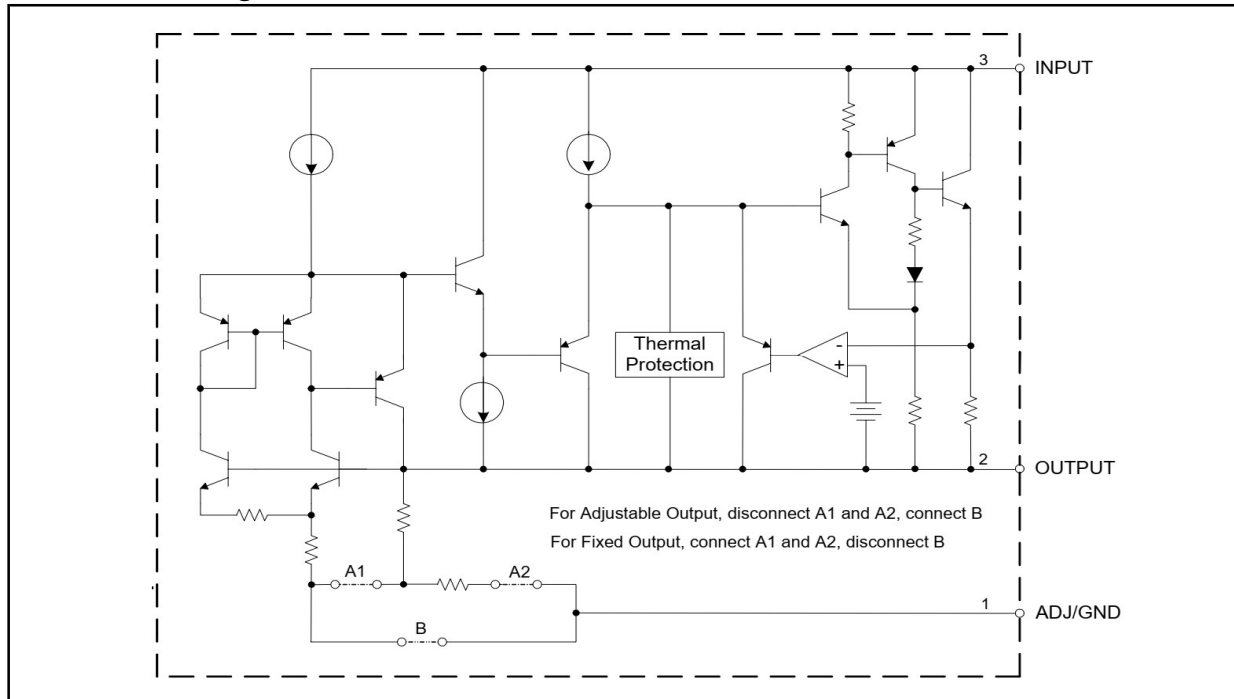
20V, 1.25A Low Dropout Voltage Linear Regulator
Functional Block Diagrams


Figure 5. Functional Block Diagram of HCR1117H

Ordering Information

HCR1117H /

Circuit Type TR: Tape&Reel

ADJ: Adjustable Output Voltage
 1V2: 1.2V 1V5: 1.5V 1V8: 1.8V
 2V5: 2.5V 2V85: 2.85V
 5V0: 5.0V 3V3: 3.3V

M1: SOT-223
 M2: SOT-89-3

Standard	Voltage	Marking ID	Package	MSL	Tape & Reel
HCR1117H/ADJM1TR	ADJ	H11A	SOT-223	MSL3	3000pcs, Tape&Reel
HCR1117H/1V2M1TR	1.2V	H18A	SOT-223	MSL3	3000pcs, Tape&Reel
HCR1117H/1V5M1TR	1.5V	H12A	SOT-223	MSL3	3000pcs, Tape&Reel
HCR1117H/1V8M1TR	1.8V	H13A	SOT-223	MSL3	3000pcs, Tape&Reel
HCR1117H/2V5M1TR	2.5V	H14A	SOT-223	MSL3	3000pcs, Tape&Reel
HCR1117H/2V85M1TR	2.85V	H15A	SOT-223	MSL3	3000pcs, Tape&Reel
HCR1117H/3V3M1TR	3.3V	H16A	SOT-223	MSL3	3000pcs, Tape&Reel
HCR1117H/5V0M1TR	5.0V	H17A	SOT-223	MSL3	3000pcs, Tape&Reel
HCR1117H/ADJM2TR	ADJ	R17A	SOT-89-3	MSL3	3000pcs, Tape&Reel
HCR1117H/1V2M2TR	1.2V	R17G	SOT-89-3	MSL3	3000pcs, Tape&Reel
HCR1117H/1V5M2TR	1.5V	R17B	SOT-89-3	MSL3	3000pcs, Tape&Reel
HCR1117H/1V8M2TR	1.8V	R17C	SOT-89-3	MSL3	3000pcs, Tape&Reel
HCR1117H/2V5M2TR	2.5V	R17D	SOT-89-3	MSL3	3000pcs, Tape&Reel
HCR1117H/2V85M2TR	2.85V	R17H	SOT-89-3	MSL3	3000pcs, Tape&Reel
HCR1117H/3V3M2TR	3.3V	R17E	SOT-89-3	MSL3	3000pcs, Tape&Reel
HCR1117H/5V0M2TR	5.0V	R17F	SOT-89-3	MSL3	3000pcs, Tape&Reel

20V, 1.25A Low Dropout Voltage Linear Regulator
Absolute Maximum Ratings(Note 1)

Parameter	Symbol	Value		Unit
Maximum Input Voltage	VIN	20		V
Operating Junction Temperature	TJ	+150		°C
Environment Temperature	Ta	+125		°C
Storage Temperature Range	TSTG	-60 to +150		°C
Lead Temperature(Soldering, 10sec)	TLEAD	260		°C
Thermal Resistance (No Heatsink, ^{note2})	θJA	SOT-89-3	165	°C/W
		SOT-223	120	
ESD (Human Body Model)	ESD	2000		V
ESD (Machine Model)	ESD	250		V

Note[1] : There are stress ratings only. Stresses exceeding the range specified under

"Absolute Maximum Ratings" may cause substantial damage to the device. Functional operation

of this device at other conditions beyond those listed in the specification is not implied and

prolonged exposure to extreme conditions may affect device reliability.

[2] Absolute maximum ratings indicate limits beyond which damage to the component may occur. Electrical specifications do not apply when operating the device outside of its operating ratings. The maximum allowable power dissipation is a function of the maximum junction temperature, TJ(max), the junction-to-ambient thermal resistance, θJA, and the ambient temperature, TA. The maximum allowable power dissipation at any ambient temperature is calculated using: $PD(max)=(TJ(max) - TA)/\theta_{JA}$. Exceeding the maximum allowable power dissipation will result in excessive die temperature, and the regulator will go into thermal shutdown.

Recommended Work Conditions

Parameter	Symbol	Min	Max	Unit
Input Supply Voltage	VIN	-	+18	V
Operating Junction Temperature	TJ	-40	+125	°C

20V, 1.25A Low Dropout Voltage Linear Regulator
Electrical Characteristics
HCR1117H-ADJ Electrical Characteristics

 (Operating Conditions: $V_{IN} \leq 10V$, $T_J = 25^\circ C$, unless otherwise specified)

Parameter	Symbol	Condition	Min	Type	Max	Unit
Reference Voltage	V_{REF}	$I_{OUT} = 10mA$, $V_{IN} - V_{OUT} = 2V$, $10mA \leq I_{OUT} \leq 1A$, $1.4V \leq V_{IN} - V_{OUT} \leq 8V$, $P \leq$ Maximum Power Dissipation	1.238 1.225	1.250 1.250	1.262 1.270	V
Line Regulation	ΔV_{OUT}	$I_{OUT} = 10mA$, $1.5V \leq V_{IN} - V_{OUT} \leq 10V$	-	0.035	0.2	%
Load Regulation	ΔV_{OUT}	$V_{IN} - V_{OUT} = 2V$, $10mA \leq I_{OUT} \leq 1A$	-	0.2	0.4	%
Dropout Voltage	V_{DROP}	$\Delta V_{REF} = 1\%$, $I_{OUT} = 0.1A$	-	1.00	1.10	V
		$\Delta V_{REF} = 1\%$, $I_{OUT} = 0.5A$	-	1.08	1.18	V
		$\Delta V_{REF} = 1\%$, $I_{OUT} = 1.0A$	-	1.15	1.25	V
Current Limit	I_{LIMIT}	$V_{IN} - V_{OUT} = 2V$	1.25	1.35	-	A
Adjust Pin Current	I_{ADJ}	$2.75V \leq V_{IN} \leq 12V$	-	60	120	μA
Adjust Pin Current Change	ΔI_{ADJ}	$1.4V \leq V_{IN} - V_{OUT} \leq 10V$, $10mA \leq I_{OUT} \leq 1A$	-	0.2	5.0	μA
Minimum Load Current (ADJ)	$I_{LOAD(MIN)}$	$1.5V \leq V_{IN} - V_{OUT} \leq 10V$ (ADJ only)	-	1.7	5.0	mA
Quiescent Current	I_Q	$V_{IN} = V_{OUT} + 1.25V$	-	5	10	mA
Ripple Rejection	PSRR	$f = 120Hz$, $C_{OUT} = 22\mu F$ Tantalum, $V_{IN} - V_{OUT} = 3V$, $I_{OUT} = 1A$	60	75	-	dB
Temperature Stability	ΔT_S		-	0.5	-	%
Long-term Stability	ΔT_{LTS}	$T_A = 125^\circ C$, 1000hrs	-	0.3	-	%
RMS Output Noise(% of V_{OUT})	ΔT_{RMS}	$T_A = 25^\circ C$, $10Hz \leq f \leq 10KHz$	-	0.003	-	%
Thermal Shutdown	T_{SHDN}	Junction Temperature	-	150	-	$^\circ C$
Thermal Shutdown Hysteresis	T_{SHDN}		-	25	-	$^\circ C$
Thermal Resistance	θ_{JC}	SOT-89-3	-	30	-	$^\circ C/W$
		SOT-223	-	25	-	

20V, 1.25A Low Dropout Voltage Linear Regulator
Electrical Characteristics (Con.)
HCR1117H-1V2 Electrical Characteristics

 (Operating Conditions: $V_{IN} \leq 10V$, $T_J = 25^\circ C$, unless otherwise specified)

Parameter	Symbol	Condition	Min	Type	Max	Unit
Output Voltage	V _{OUT}	I _{OUT} =10mA, V _{IN} =3.2V, 10mA≤I _{OUT} ≤1A, 3.0V≤V _{IN} ≤10V	1.176	1.20	1.224	V
			1.152	1.20	1.248	
Line Regulation	ΔV _{OUT}	I _{OUT} =10mA, 1.5V≤V _{IN} - V _{OUT} ≤10V	-	1	6	mV
Load Regulation	ΔV _{OUT}	V _{IN} -V _{OUT} =2V, 10mA≤I _{OUT} ≤1A	-	1	10	mV
Dropout Voltage	V _{DROP}	ΔV _{OUT} =1%, I _{OUT} =0.1A	-	1.00	1.10	V
		ΔV _{OUT} =1%, I _{OUT} =0.5A	-	1.08	1.18	V
		ΔV _{OUT} =1%, I _{OUT} =1.0A	-	1.15	1.25	V
Current Limit	I _{LIMIT}	V _{IN} -V _{OUT} =2V	1.25	1.35	-	A
Quiescent Current	I _Q	V _{IN} =V _{OUT} +1.25V	-	5	10	mA
Ripple Rejection	PSRR	f=120Hz, C _{OUT} =22uF Tantalum, V _{IN} -V _{OUT} =3V, I _{OUT} =1A	60	75	-	dB
Temperature Stability	ΔT _S		-	0.5	-	%
Long-term Stability	ΔT _{LTS}	T _A =125°C, 1000hrs	-	0.3	-	%
RMS Output Noise(% of V _{OUT})	ΔT _{RMS}	T _A =25°C, 10Hz≤f≤10KHz	-	0.003	-	%
Thermal Shutdown	T _{SHDN}	Junction Temperature	-	150	-	°C
Thermal Shutdown Hysteresis	T _{SHDN}		-	25	-	°C
Thermal Resistance	θ _{JC}	SOT-89-3	-	30	-	'C/W
		SOT-223	-	25	-	

20V, 1.25A Low Dropout Voltage Linear Regulator
Electrical Characteristics (Con.)
HCR1117H-1V5 Electrical Characteristics

 (Operating Conditions: $V_{IN} \leq 10V$, $T_J = 25^\circ C$, unless otherwise specified)

Parameter	Symbol	Condition	Min	Type	Max	Unit
Output Voltage	V_{OUT}	$I_{OUT} = 10mA$, $V_{IN} = 3.5V$, $10mA \leq I_{OUT} \leq 1A$, $3V \leq V_{IN} \leq 10V$	1.485	1.50	1.515	V
			1.470	1.50	1.530	
Line Regulation	ΔV_{OUT}	$I_{OUT} = 10mA$, $1.5V \leq V_{IN} - V_{OUT} \leq 10V$	-	1	6	mV
Load Regulation	ΔV_{OUT}	$V_{IN} - V_{OUT} = 2V$, $10mA \leq I_{OUT} \leq 1A$	-	1	10	mV
Dropout Voltage	V_{DROP}	$\Delta V_{OUT} = 1\%$, $I_{OUT} = 0.1A$	-	1.00	1.10	V
		$\Delta V_{OUT} = 1\%$, $I_{OUT} = 0.5A$	-	1.08	1.18	V
		$\Delta V_{OUT} = 1\%$, $I_{OUT} = 1.0A$	-	1.15	1.25	V
Current Limit	I_{LIMIT}	$V_{IN} - V_{OUT} = 2V$	1.25	1.35	-	A
Quiescent Current	I_Q	$V_{IN} = V_{OUT} + 1.25V$	-	5	10	mA
Ripple Rejection	PSRR	$f = 120Hz$, $C_{OUT} = 22\mu F$ Tantalum, $V_{IN} - V_{OUT} = 3V$, $I_{OUT} = 1A$	60	75	-	dB
Temperature Stability	ΔT_S		-	0.5	-	%
Long-term Stability	ΔT_{LTS}	$T_A = 125^\circ C$, 1000hrs	-	0.3	-	%
RMS Output Noise(% of V_{OUT})	ΔT_{RMS}	$T_A = 25^\circ C$, $10Hz \leq f \leq 10KHz$	-	0.003	-	%
Thermal Shutdown	T_{SHDN}	Junction Temperature	-	150	-	$^\circ C$
Thermal Shutdown Hysteresis	T_{SHDN}		-	25	-	$^\circ C$
Thermal Resistance	θ_{JC}	SOT-89-3	-	30	-	$^\circ C/W$
		SOT-223	-	25	-	

20V, 1.25A Low Dropout Voltage Linear Regulator
Electrical Characteristics (Con.)
HCR1117H-1V8 Electrical Characteristics

 (Operating Conditions: $V_{IN} \leq 10V$, $T_J = 25^\circ C$, unless otherwise specified)

Parameter	Symbol	Condition	Min	Type	Max	Unit
Output Voltage	V_{OUT}	$I_{OUT} = 10mA$, $V_{IN} = 3.8V$, $10mA \leq I_{OUT} \leq 1A$, $3.2V \leq V_{IN} \leq 10V$	1.782	1.80	1.818	V
			1.746	1.80	1.854	
Line Regulation	ΔV_{OUT}	$I_{OUT} = 10mA$, $1.5V \leq V_{IN} - V_{OUT} \leq 10V$	-	1	6	mV
Load Regulation	ΔV_{OUT}	$V_{IN} - V_{OUT} = 2V$, $10mA \leq I_{OUT} \leq 1A$	-	1	10	mV
Dropout Voltage	V_{DROP}	$\Delta V_{OUT} = 1\%$, $I_{OUT} = 0.1A$	-	1.00	1.10	V
		$\Delta V_{OUT} = 1\%$, $I_{OUT} = 0.5A$	-	1.08	1.18	V
		$\Delta V_{OUT} = 1\%$, $I_{OUT} = 1.0A$	-	1.15	1.25	V
Current Limit	I_{LIMIT}	$V_{IN} - V_{OUT} = 2V$	1.25	1.35	-	A
Quiescent Current	I_Q	$V_{IN} = V_{OUT} + 1.25V$	-	5	10	mA
Ripple Rejection	PSRR	$f = 120Hz$, $C_{OUT} = 22\mu F$ Tantalum, $V_{IN} - V_{OUT} = 3V$, $I_{OUT} = 1A$	60	75	-	dB
Temperature Stability	ΔT_S		-	0.5	-	%
Long-term Stability	ΔT_{LTS}	$T_A = 125^\circ C$, 1000hrs	-	0.3	-	%
RMS Output Noise(% of V_{OUT})	ΔT_{RMS}	$T_A = 25^\circ C$, $10Hz \leq f \leq 10KHz$	-	0.003	-	%
Thermal Shutdown	T_{SHDN}	Junction Temperature	-	150	-	$^\circ C$
Thermal Shutdown Hysteresis	T_{SHDN}		-	25	-	$^\circ C$
Thermal Resistance	θ_{JC}	SOT-89-3	-	30	-	$^\circ C/W$
		SOT-223	-	25	-	

20V, 1.25A Low Dropout Voltage Linear Regulator
Electrical Characteristics (Con.)
HCR1117H-2V5 Electrical Characteristics

 (Operating Conditions: $V_{IN} \leq 10V$, $T_J = 25^\circ C$, unless otherwise specified)

Parameter	Symbol	Condition	Min	Type	Max	Unit
Output Voltage	V_{OUT}	$I_{OUT} = 10mA$, $V_{IN} = 4.5V$, $10mA \leq I_{OUT} \leq 1A$, $3.9V \leq V_{IN} \leq 10V$	2.475	2.50	2.525	V
			2.450	2.50	2.550	
Line Regulation	ΔV_{OUT}	$I_{OUT} = 10mA$, $1.5V \leq V_{IN} - V_{OUT} \leq 10V$	-	1	6	mV
Load Regulation	ΔV_{OUT}	$V_{IN} - V_{OUT} = 2V$, $10mA \leq I_{OUT} \leq 1A$	-	1	10	mV
Dropout Voltage	V_{DROP}	$\Delta V_{OUT} = 1\%$, $I_{OUT} = 0.1A$	-	1.00	1.10	V
		$\Delta V_{OUT} = 1\%$, $I_{OUT} = 0.5A$	-	1.08	1.18	V
		$\Delta V_{OUT} = 1\%$, $I_{OUT} = 1.0A$	-	1.15	1.25	V
Current Limit	I_{LIMIT}	$V_{IN} - V_{OUT} = 2V$	1.25	1.35	-	A
Quiescent Current	I_Q	$V_{IN} = V_{OUT} + 1.25V$	-	5	10	mA
Ripple Rejection	PSRR	$f = 120Hz$, $C_{OUT} = 22\mu F$ Tantalum, $V_{IN} - V_{OUT} = 3V$, $I_{OUT} = 1A$	60	75	-	dB
Temperature Stability	ΔT_S		-	0.5	-	%
Long-term Stability	ΔT_{LTS}	$T_A = 125^\circ C$, 1000hrs	-	0.3	-	%
RMS Output Noise(% of V_{OUT})	ΔT_{RMS}	$T_A = 25^\circ C$, $10Hz \leq f \leq 10KHz$	-	0.003	-	%
Thermal Shutdown	T_{SHDN}	Junction Temperature	-	150	-	$^\circ C$
Thermal Shutdown Hysteresis	T_{SHDN}		-	25	-	$^\circ C$
Thermal Resistance	θ_{JC}	SOT-89-3	-	30	-	$^\circ C/W$
		SOT-223	-	25	-	

20V, 1.25A Low Dropout Voltage Linear Regulator
Electrical Characteristics (Con.)
HCR1117H-2V85 Electrical Characteristics

 (Operating Conditions: $V_{IN} \leq 10V$, $T_J = 25^\circ C$, unless otherwise specified)

Parameter	Symbol	Condition	Min	Type	Max	Unit
Output Voltage	V_{OUT}	$I_{OUT} = 10mA$, $V_{IN} = 4.85V$, $10mA \leq I_{OUT} \leq 1A$, $4.25V \leq V_{IN} \leq 10V$	2.822	2.850	2.878	V
			2.793	2.850	2.907	
Line Regulation	ΔV_{OUT}	$I_{OUT} = 10mA$, $1.5V \leq V_{IN} - V_{OUT} \leq 10V$	-	1	6	mV
Load Regulation	ΔV_{OUT}	$V_{IN} - V_{OUT} = 2V$, $10mA \leq I_{OUT} \leq 1A$	-	1	10	mV
Dropout Voltage	V_{DROP}	$\Delta V_{OUT} = 1\%$, $I_{OUT} = 0.1A$	-	1.00	1.10	V
		$\Delta V_{OUT} = 1\%$, $I_{OUT} = 0.5A$	-	1.08	1.18	V
		$\Delta V_{OUT} = 1\%$, $I_{OUT} = 1.0A$	-	1.15	1.25	V
Current Limit	I_{LIMIT}	$V_{IN} - V_{OUT} = 2V$	1.25	1.35	-	A
Quiescent Current	I_Q	$V_{IN} = V_{OUT} + 1.25V$	-	5	10	mA
Ripple Rejection	PSRR	$f = 120Hz$, $C_{OUT} = 22\mu F$ Tantalum, $V_{IN} - V_{OUT} = 3V$, $I_{OUT} = 1A$	60	75	-	dB
Temperature Stability	ΔT_S		-	0.5	-	%
Long-term Stability	ΔT_{LTS}	$T_A = 125^\circ C$, 1000hrs	-	0.3	-	%
RMS Output Noise(% of V_{OUT})	ΔT_{RMS}	$T_A = 25^\circ C$, $10Hz \leq f \leq 10KHz$	-	0.003	-	%
Thermal Shutdown	T_{SHDN}	Junction Temperature	-	150	-	$^\circ C$
Thermal Shutdown Hysteresis	T_{SHDN}		-	25	-	$^\circ C$
Thermal Resistance	θ_{JC}	SOT-89-3	-	30	-	$^\circ C/W$
		SOT-223	-	25	-	

20V, 1.25A Low Dropout Voltage Linear Regulator
Electrical Characteristics (Con.)
HCR1117H-3V3 Electrical Characteristics

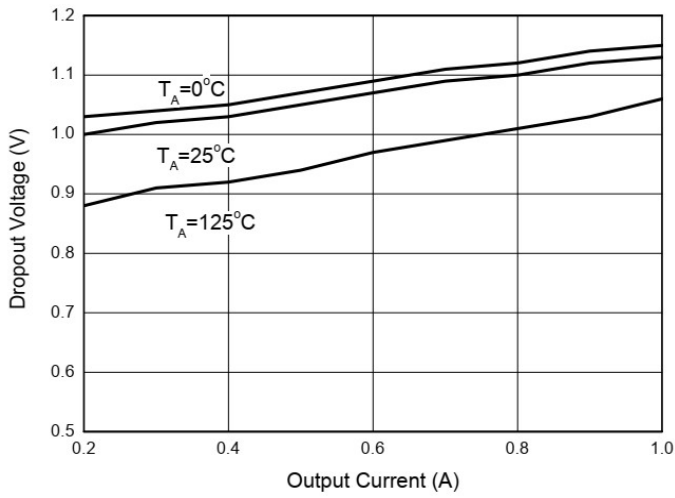
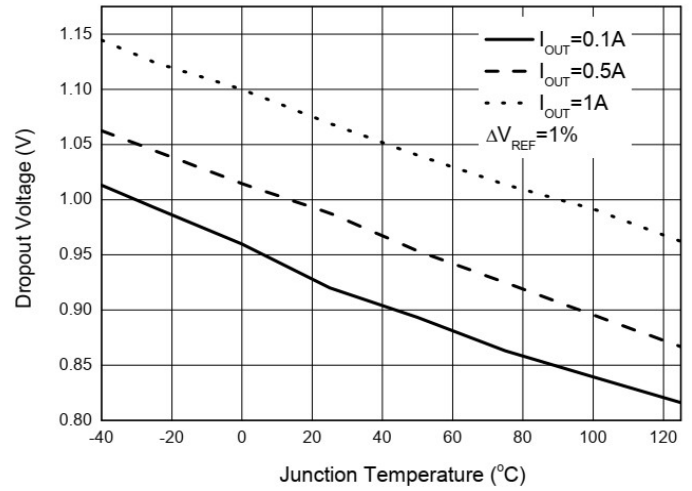
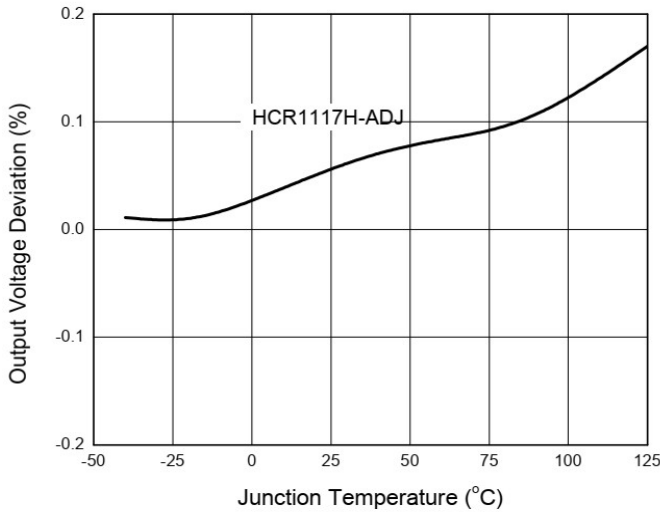
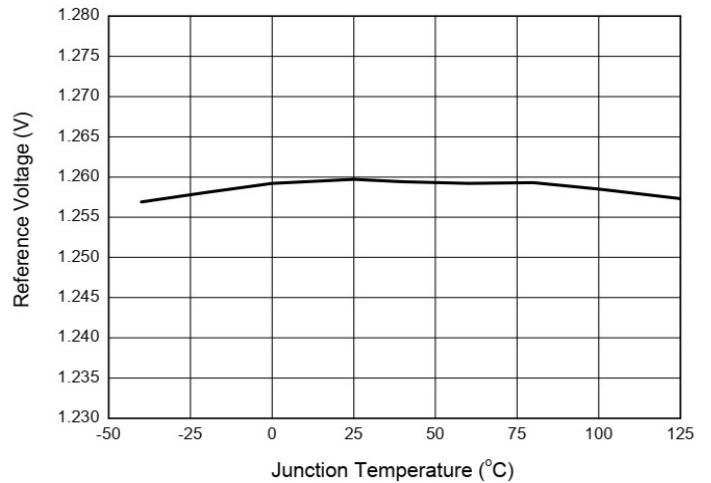
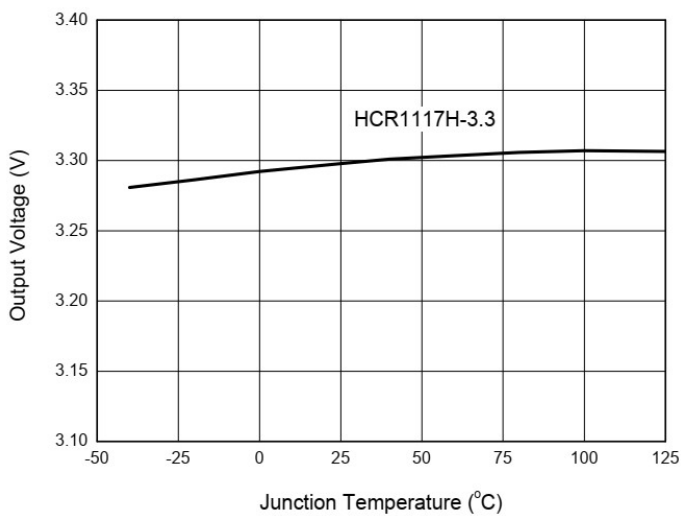
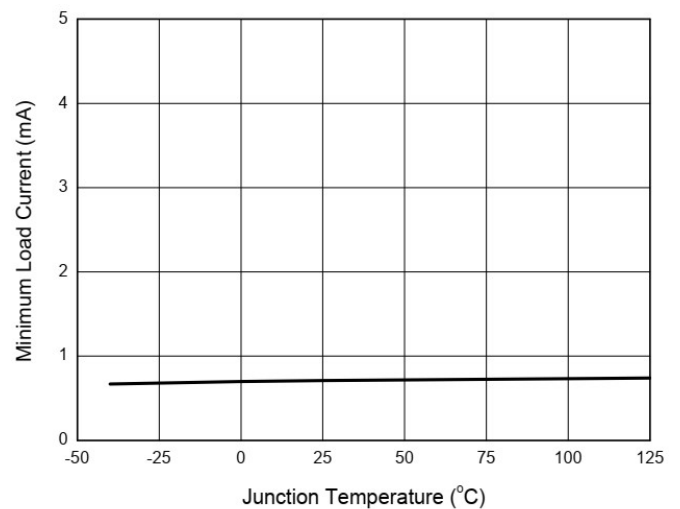
 (Operating Conditions: $V_{IN} \leq 10V$, $T_J = 25^\circ C$, unless otherwise specified)

Parameter	Symbol	Condition	Min	Type	Max	Unit
Output Voltage	V_{OUT}	$I_{OUT} = 10mA$, $V_{IN} = 5.0V$, $10mA \leq I_{OUT} \leq 1A$, $4.75V \leq V_{IN} \leq 10V$	3.267	3.30	3.333	V
			3.235	3.30	3.365	
Line Regulation	ΔV_{OUT}	$I_{OUT} = 10mA$, $1.5V \leq V_{IN} - V_{OUT} \leq 10V$	-	1	6	mV
Load Regulation	ΔV_{OUT}	$V_{IN} - V_{OUT} = 2V$, $10mA \leq I_{OUT} \leq 1A$	-	1	10	mV
Dropout Voltage	V_{DROP}	$\Delta V_{OUT} = 1\%$, $I_{OUT} = 0.1A$	-	1.00	1.10	V
		$\Delta V_{OUT} = 1\%$, $I_{OUT} = 0.5A$	-	1.08	1.18	V
		$\Delta V_{OUT} = 1\%$, $I_{OUT} = 1.0A$	-	1.15	1.25	V
Current Limit	I_{LIMIT}	$V_{IN} - V_{OUT} = 2V$	1.25	1.35	-	A
Quiescent Current	I_Q	$V_{IN} = V_{OUT} + 1.25V$	-	5	10	mA
Ripple Rejection	PSRR	$f = 120Hz$, $C_{OUT} = 22\mu F$ Tantalum, $V_{IN} - V_{OUT} = 3V$, $I_{OUT} = 1A$	60	75	-	dB
Temperature Stability	ΔT_S		-	0.5	-	%
Long-term Stability	ΔT_{LTS}	$T_A = 125^\circ C$, 1000hrs	-	0.3	-	%
RMS Output Noise(% of V_{OUT})	ΔT_{RMS}	$T_A = 25^\circ C$, $10Hz \leq f \leq 10KHz$	-	0.003	-	%
Thermal Shutdown	T_{SHDN}	Junction Temperature	-	150	-	'C
Thermal Shutdown Hysteresis	T_{SHDN}		-	25	-	'C
Thermal Resistance	θ_{JC}	SOT-89-3	-	30	-	'C/W
		SOT-223	-	25	-	

20V, 1.25A Low Dropout Voltage Linear Regulator
Electrical Characteristics (Con.)
HCR1117H-5V0 Electrical Characteristics

 (Operating Conditions: $V_{IN} \leq 10V$, $T_J = 25^\circ C$, unless otherwise specified)

Parameter	Symbol	Condition	Min	Type	Max	Unit
Output Voltage	V_{OUT}	$I_{OUT} = 10mA$, $V_{IN} = 7.0V$, $10mA \leq I_{OUT} \leq 1A$, $6.5V \leq V_{IN} \leq 12V$	4.95	5.00	5.05	V
			4.90	5.00	5.10	
Line Regulation	ΔV_{OUT}	$I_{OUT} = 10mA$, $1.5V \leq V_{IN} - V_{OUT} \leq 10V$	-	1	10	mV
Load Regulation	ΔV_{OUT}	$V_{IN} - V_{OUT} = 2V$, $10mA \leq I_{OUT} \leq 1A$	-	1	15	mV
Dropout Voltage	V_{DROP}	$\Delta V_{OUT} = 1\%$, $I_{OUT} = 0.1A$	-	1.00	1.10	V
		$\Delta V_{OUT} = 1\%$, $I_{OUT} = 0.5A$	-	1.08	1.18	V
		$\Delta V_{OUT} = 1\%$, $I_{OUT} = 1.0A$	-	1.15	1.25	V
Current Limit	I_{LIMIT}	$V_{IN} - V_{OUT} = 2V$	1.25	1.35	-	A
Quiescent Current	I_Q	$V_{IN} = V_{OUT} + 1.25V$	-	5	10	mA
Ripple Rejection	PSRR	$f = 120Hz$, $C_{OUT} = 22\mu F$ Tantalum, $V_{IN} - V_{OUT} = 3V$, $I_{OUT} = 1A$	60	75	-	dB
Temperature Stability	ΔT_S		-	0.5	-	%
Long-term Stability	ΔT_{LTS}	$T_A = 125^\circ C$, 1000hrs	-	0.3	-	%
RMS Output Noise(% of V_{OUT})	ΔT_{RMS}	$T_A = 25^\circ C$, $10Hz \leq f \leq 10KHz$	-	0.003	-	%
Thermal Shutdown	T_{SHDN}	Junction Temperature	-	150	-	$^\circ C$
Thermal Shutdown Hysteresis	T_{SHDN}		-	25	-	$^\circ C$
Thermal Resistance	θ_{JC}	SOT-89-3	-	30	-	$^\circ C/W$
		SOT-223	-	25	-	

20V, 1.25A Low Dropout Voltage Linear Regulator
Typical Performance Characteristics:

Figure 6. Dropout Voltage vs. Output Current

Figure 7. Dropout Voltage vs. Junction Temperature

Figure 8. Load Regulation vs. Junction Temperature

Figure 9. Reference Voltage vs. Junction Temperature

Figure 10. Output Voltage vs. Junction Temperature

Figure 11. Minimum Load Current vs. Junction Temperature

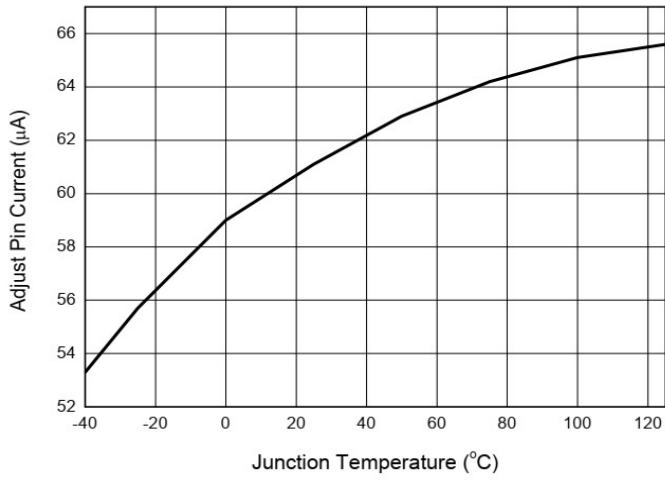
20V, 1.25A Low Dropout Voltage Linear Regulator
Typical Performance Characteristics: (Con.)


Figure 12. Adjust Pin Current vs. Junction Temperature

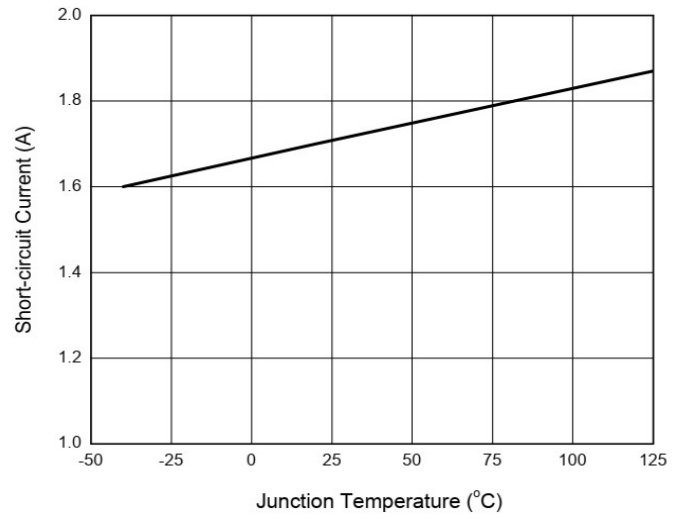


Figure 13. Short-Circuit Current vs. Junction Temperature

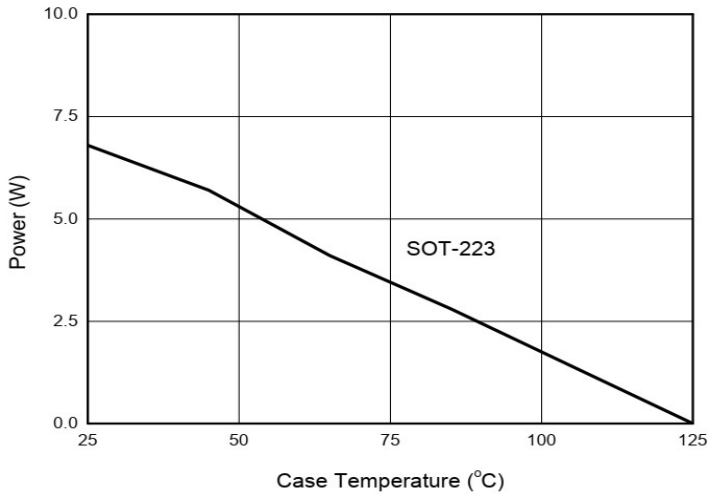


Figure 14. Maximum Power Dissipation

(Conditions: $V_{IN}=4.8V$ to $5.8V$, $V_{OUT}=3.33V$, $I_{OUT}=0.1A$, $C_{IN}=1\mu F$, $C_{OUT}=10\mu F$)

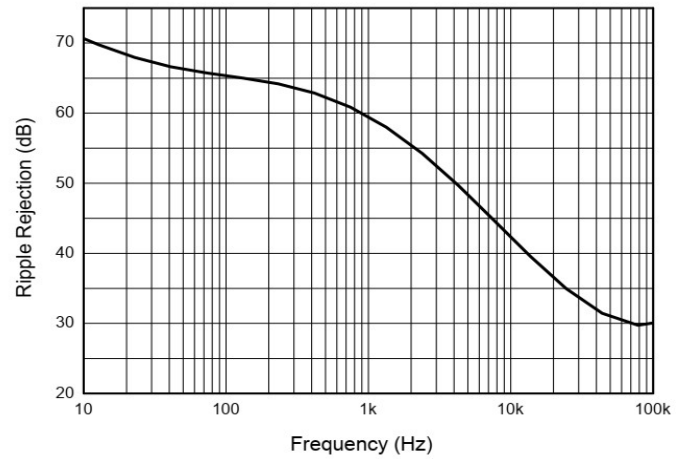


Figure 15. Ripple Rejection vs. Frequency

(Conditions: $V_{IN}=4.8V$, $V_{OUT}=3.33V$, $I_{OUT}=0.1A$ to $0.5A$, $C_{IN}=C_{OUT}=10\mu F$)

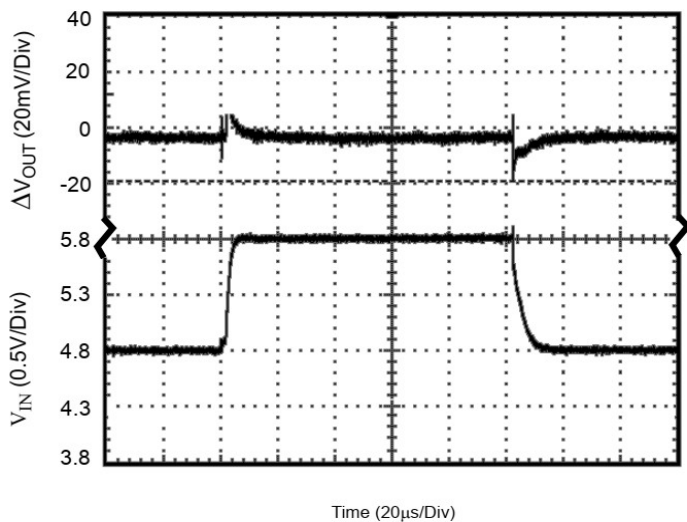


Figure 16. Line Transient Response

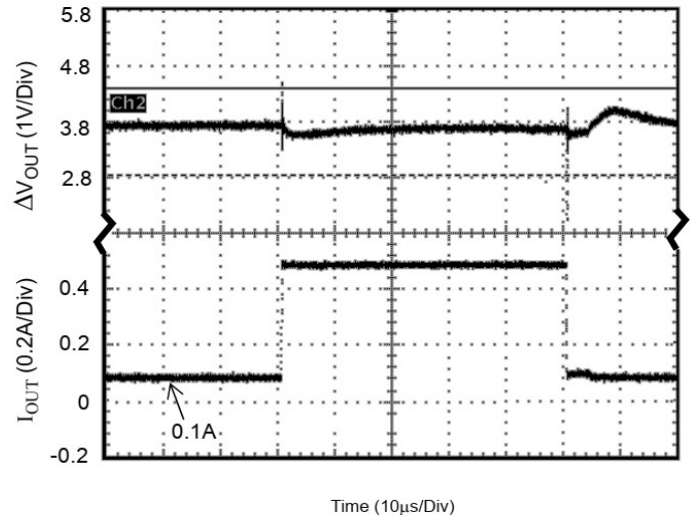


Figure 17. Load Transient Response

20V, 1.25A Low Dropout Voltage Linear Regulator

Detailed Description:

The HCR1117H is a series of low dropout voltage, three terminal regulators. Its application circuit is very simple: the fixed version only needs two capacitors and the adjustable version only needs two resistors and two capacitors to work. It is composed of some modules including start-up circuit, bias circuit, bandgap, thermal shutdown, current limit, power transistors and its driver circuit and so on.

The thermal shut down and current limit modules can assure chip and its application system working safety when the junction temperature is larger than 140°C or output current is larger Constant junction temperature. The Curve of Load Regulation VS. Temperature is than 1.4A.

The bandgap module provides stable reference voltage, whose temperature coefficient is compensated by careful design considerations. The temperature coefficient is under 100ppm/°C And the accuracy of output voltage is guaranteed by trimming technique.

Typical Application:

The HCR1117H has an adjustable version and five fixed versions, Figure 18. is its typical application:

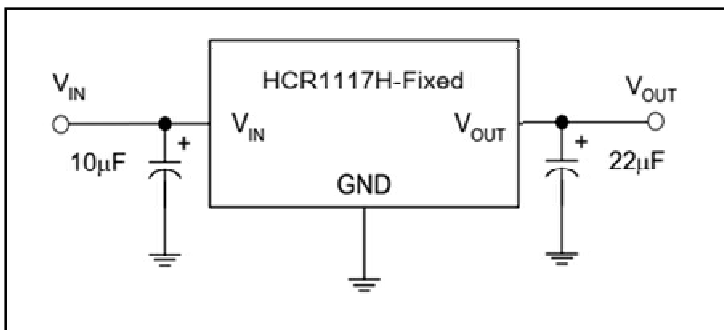


Figure 18. Application circuit of HCR1117H-Fixed version

Application Hints:

1. Recommend using 10uF tan capacitor as bypass capacitor (C1) for all application circuit.

Application Hints(Con.)

2. Recommend using 10uF or from 10uF to 22uF tan capacitor (C2) to assure circuit stability .

Output Voltage Of Adjustable Version:

The HCR1117H adjustable version provide 1.25V reference voltage. Any output voltage between 1.25V to 13.8V can be available by choosing two external resistors(connection method is shown in Figure 19.

The R1, R2 is the two external resistors.

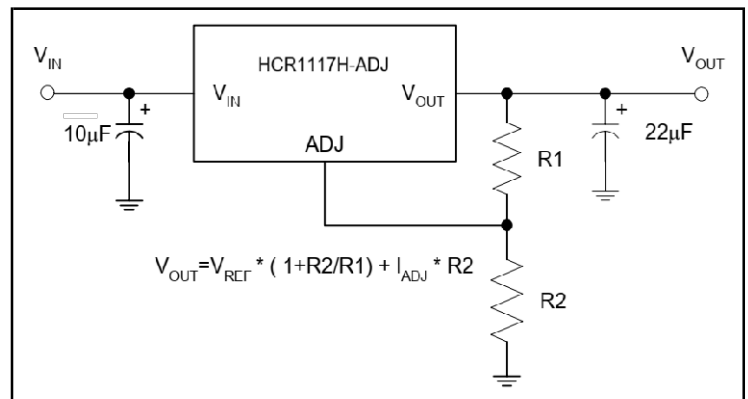


Figure 19. Application circuit of HCR1117H-ADJ version

Explanation :

The output voltage of adjustable version satisfies this followed equation

$$V_{out} = V_{ref} * (1 + R2/R1) + I_{adj} * R2.$$

We can ignore I_{adj} because I_{adj} (about 50uA) is much less than the current of R1(about 4mA).

How to choose R1: The value of R1 should be in the range of 200Ω - 350Ω to assure chip working normally without any load. To assure the electrical performance showed in table 1

the output current should be larger than 5mA . If R1 is too large, the minimum output current should be larger than 4mA , The best working condition is to assure that the output current exceeds 10mA

20V, 1.25A Low Dropout Voltage Linear Regulator
Detailed Description(Con.)
Thermal Considerations:

We have to take heat dissipation into consideration when output current or differential voltage of input and output voltage is large. Because in such cases, the power dissipation consumed by HCR1117H is very large.

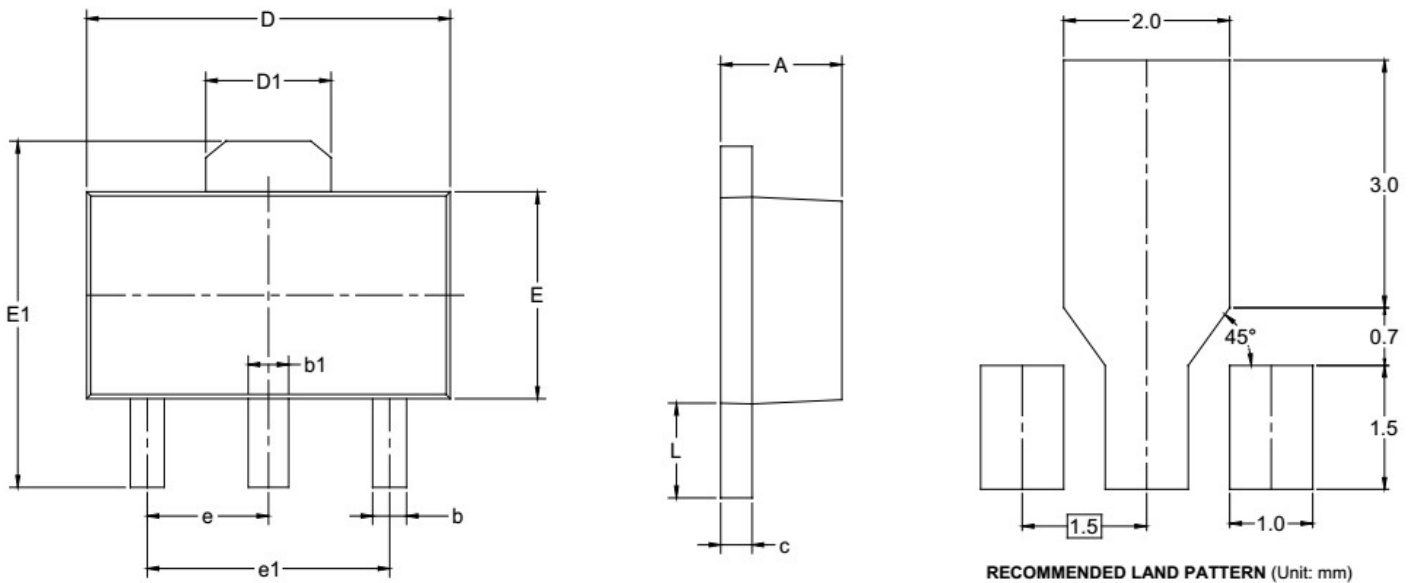
The HCR1117H series uses SOT-89 and SOT-223 package type and its thermal resistance is about 25°C/W .

And the copper area of application board can affect the total thermal resistance. if copper area is 5cm * 5cm (two sides) , the resistance is about 30°C/W. So total thermal resistance is about 25°C/W + 30°C/W. We can decrease total thermal resistance by increasing copper area in application board.

Mechanical Dimensions

SOT-89-3 (M2) Package.

unit: mm

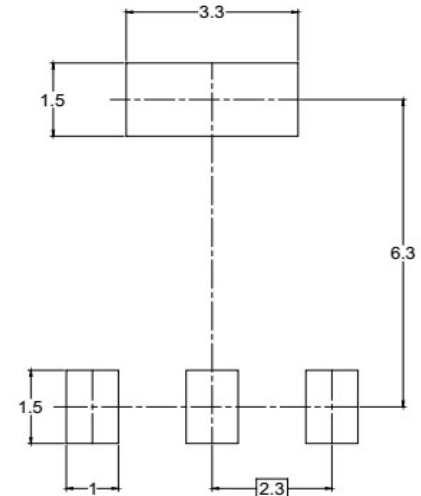
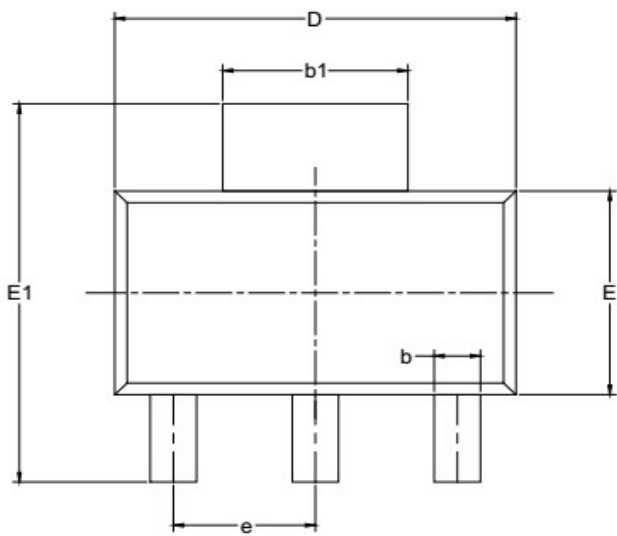
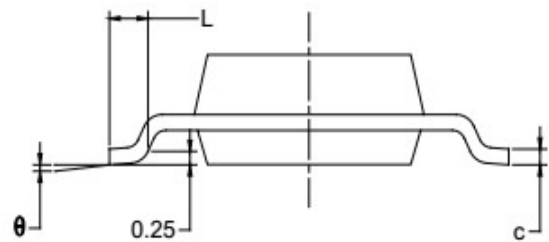
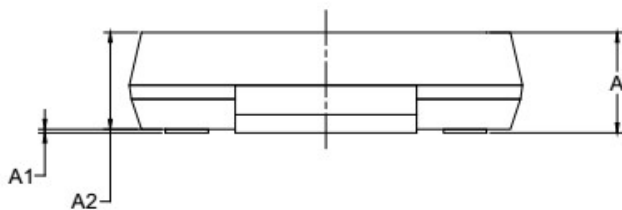


Symbol	Dimensions In Millimeters		Dimensions In Inches	
	MIN	MAX	MIN	MAX
A	1.400	1.600	0.055	0.063
b	0.320	0.520	0.013	0.020
b1	0.400	0.580	0.016	0.023
c	0.350	0.440	0.014	0.017
D	4.400	4.600	0.173	0.181
D1	1.550 REF		0.061 REF	
E	2.300	2.600	0.091	0.102
E1	3.940	4.250	0.155	0.167
e	1.500 TYP		0.060 TYP	
e1	3.000 TYP		0.118 TYP	
L	0.900	1.200	0.035	0.047

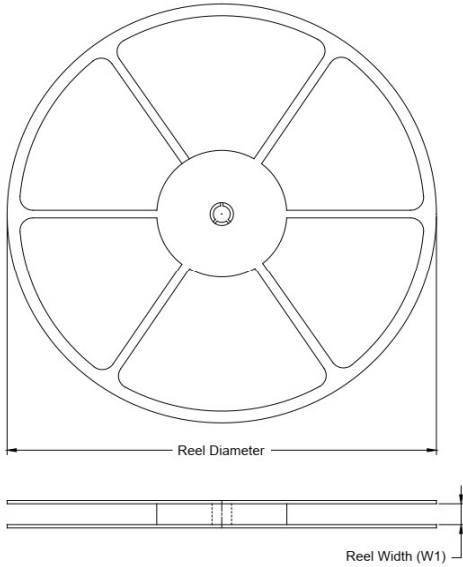
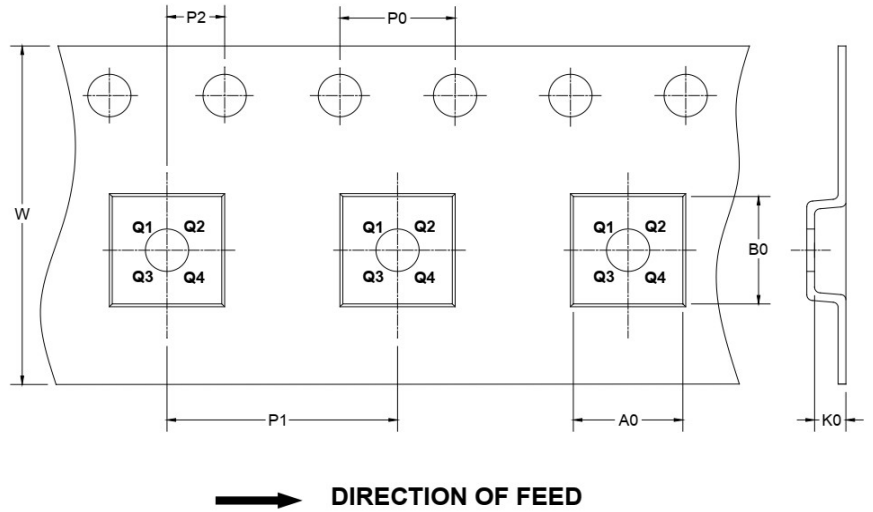
20V, 1.25A Low Dropout Voltage Linear Regulator
Mechanical Dimensions(Con.)

SOT-223 (M1) Package.

unit: mm


RECOMMENDED LAND PATTERN (Unit: mm)


Symbol	Dimensions In Millimeters		Dimensions In Inches	
	MIN	MAX	MIN	MAX
A		1.800		0.071
A1	0.020	0.100	0.001	0.004
A2	1.500	1.700	0.059	0.067
b	0.660	0.840	0.026	0.033
b1	2.900	3.100	0.114	0.122
c	0.230	0.350	0.009	0.014
D	6.300	6.700	0.248	0.264
E	3.300	3.700	0.130	0.146
E1	6.700	7.300	0.264	0.287
e	2.300 BSC		0.091 BSC	
L	0.750		0.030	
θ	0°	10°	0°	10°

TAPE AND REEL INFORMATION
REEL DIMENSIONS

TAPE DIMENSIONS


NOTE: The picture is only for reference. Please make the object as the standard.

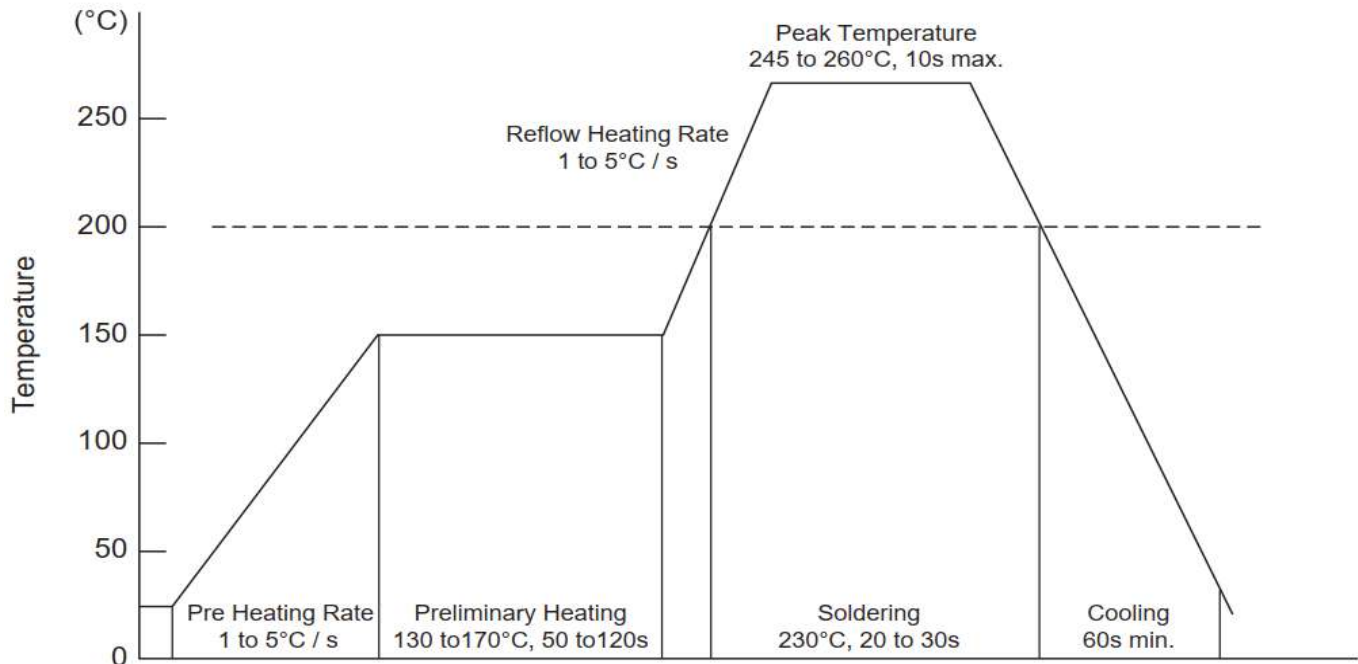
KEY PARAMETER LIST OF TAPE AND REEL

Package Type	Reel Diameter	Reel Width W1 (mm)	A0 (mm)	B0 (mm)	K0 (mm)	P0 (mm)	P1 (mm)	P2 (mm)	W (mm)	Pin1 Quadrant
SOT-89-3	7"	13.2	4.85	4.45	1.85	4.0	8.0	2.0	12.0	Q3
SOT-223	13"	12.4	6.55	7.25	1.90	4.0	8.0	2.0	12.0	Q3

20V, 1.25A Low Dropout Voltage Linear Regulator

Conditions of Soldering and Storage

• Recommended condition of reflow soldering



Recommended peak temperature is over 245°C, if peak temperature is below 245°C, you may adjust the following parameters:

- * Time length of peak temperature (longer)
- * Time length of soldering (longer)
- * Thickness of solder paste (thicker)

• Conditions of hand soldering

- * Temperature : 300°C
- * Time : 3s max
- * Times : one time

• Storage conditions

- * Temperature
5 to 40°C
- * Humidity
30 to 80% RH
- * Recommended period
One year after manufacturing