

6V, 300mA, 2uA Low Iq, Low Dropout Voltage Linear Regulator

Features

- 300mA Output Current
- 1.2V to 5.5V Input Voltage Range
- 2uA Ground Current at no Load
- 10nA Disable Current (By option)
- $\pm 2\%$ Output Accuracy
- Dropout Voltage: 0.18V at 300mA/ V_{OUT} 3.3V
- Current Limit Protection
- Support Fixed Output Voltage: 1.2V, 1.5V, 1.6V, 1.8V, 2.5V, 2.8V, 3.0V and 3.3V
- Stable with Ceramic or Tantalum Capacitor
- Over-Temperature Protection
- SOT23-3, SOT23-5, UTDFN-1X1-4L and DFN-2X2-6L Packages Available

Applications

- Portable, Battery Powered Equipment
- Low Power Microcontrollers
- Laptop, Palmtops and PDAs
- Wireless Communication Equipment
- Audio/Video Equipment
- Car Navigation Systems

General Description

The HCR2136 series are a group of low-dropout(LDO) voltage regulators offering the benefits of wide input voltage range from 1.2V to 5.5V, low dropout voltage low power consumption, and miniaturized packaging. Quiescent current of only 2 μ A makes these devices ideal for powering the battery-powered, always-on systems that require very little idle-state power dissipation to a longer service life. There is an option of shutdown mode by selecting the parts with the EN pin and pulling it low. The shutdown current in this mode goes down to only 100nA (typical).

The HCR2136 series of linear regulators are stable with the ceramic output capacitor over its wide input range from 1.2V to 5.5V and the entire range of output load current (0mA to 300mA).

It is rated over the -40°C to +85°C temperature range.

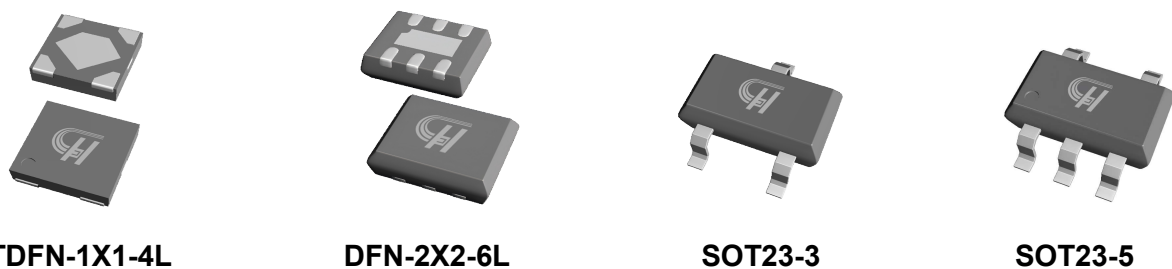

Figure 1. Package Type of HCR2136

6V, 300mA, 2uA Low Iq, Low Dropout Voltage Linear Regulator
Pin Configuration

Figure 2. Pin Configuration of SWLD2136 (Top View)

Pin Function Table

HCR2136				Name	Function
UTDFN 1X1-4L	DFN2X2-6L	SOT-23-5	SOT23-3		
1	1	5	2	Vout	Output of the regulator
2	3	2	1	GND	Ground Pin
3	4	3	-	EN	Enable Control Input
4	6	1	3	VIN	Input of Supply Voltage
-	2,5	4	-	NC	No internal Connection
-	-	4	-	SNS	Sense of Output Voltage
Exposed Pad	Exposed Pad	-	-	SGND	Substrate of Chip. Leave floating or tie to GND

6V, 300mA, 2uA Low Iq, Low Dropout Voltage Linear Regulator
Typical Application Circuit
-Fixed Vout Circuit and with EN control function

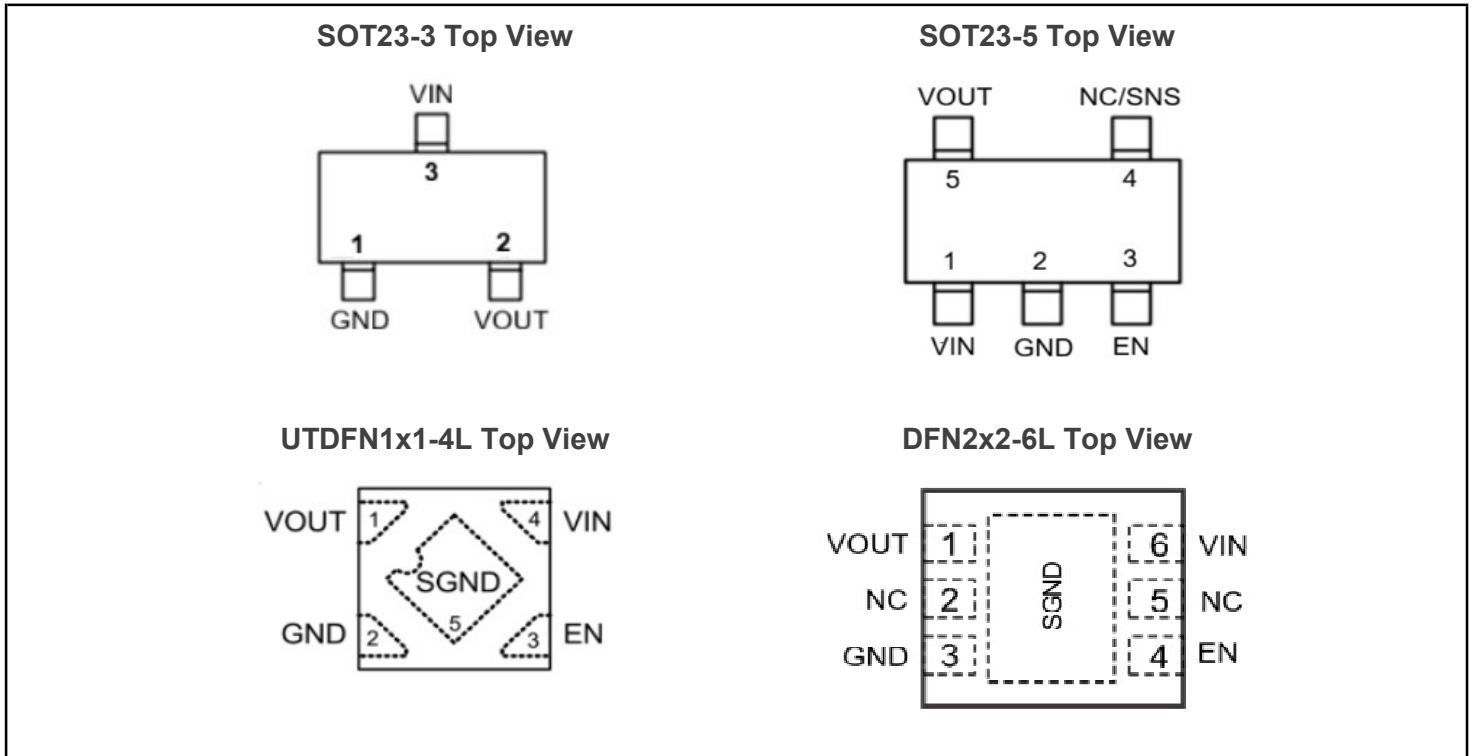
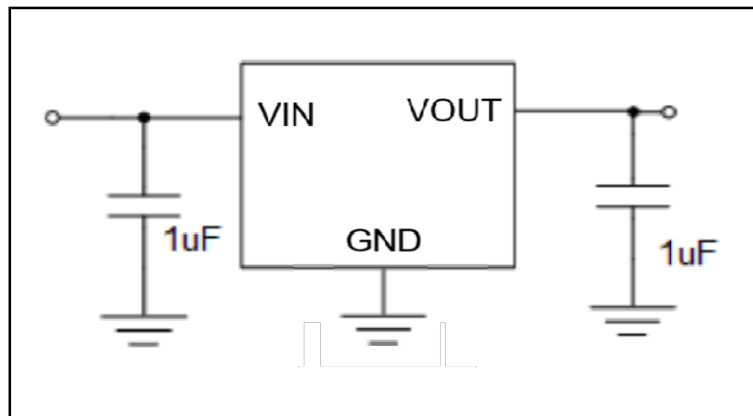
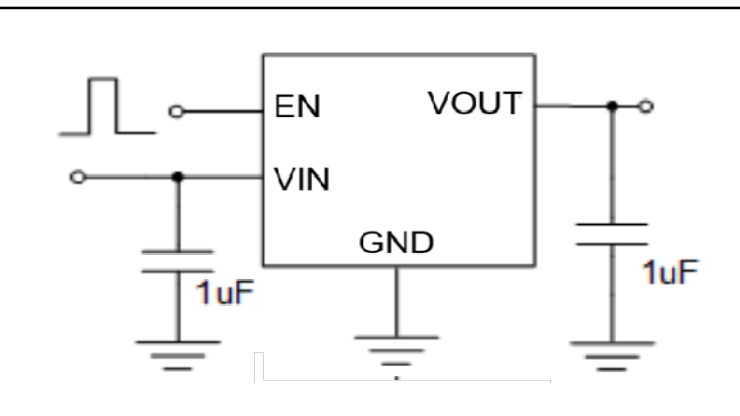
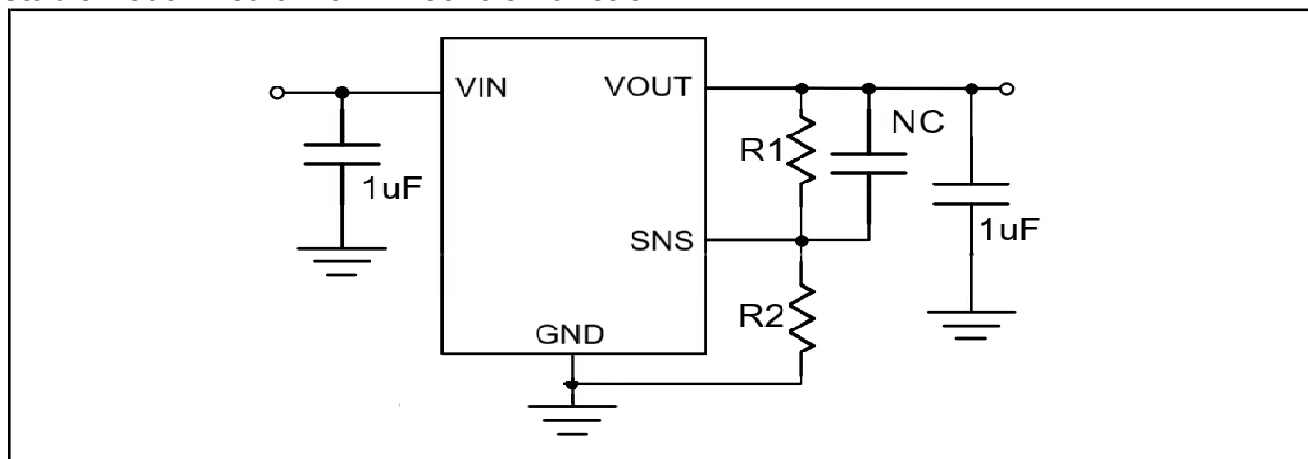
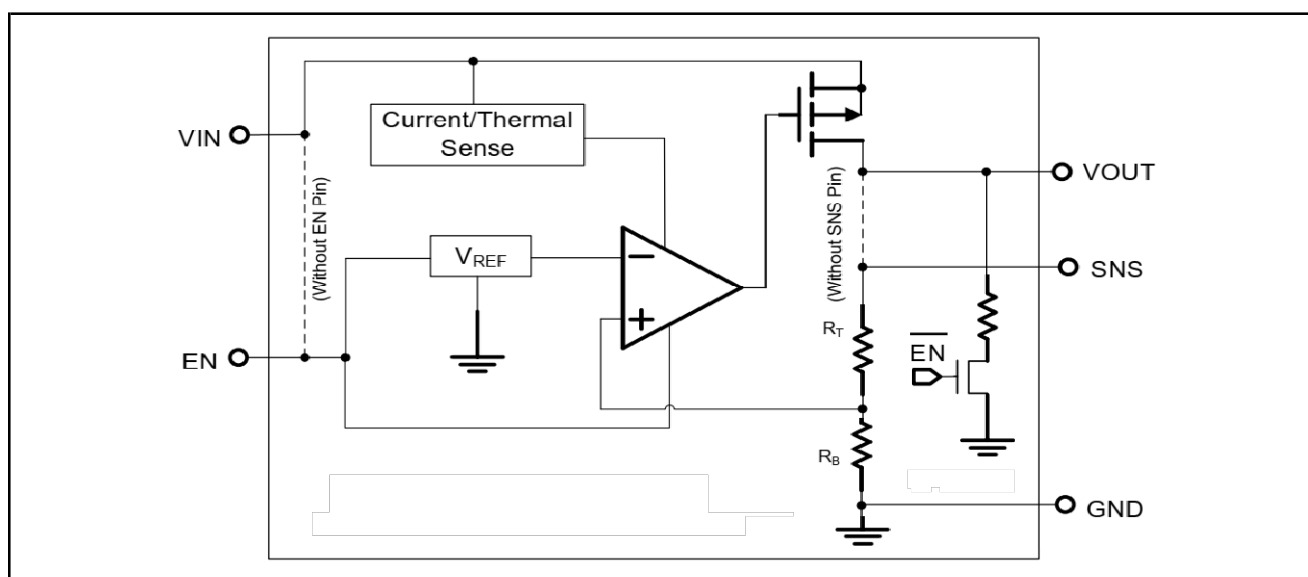
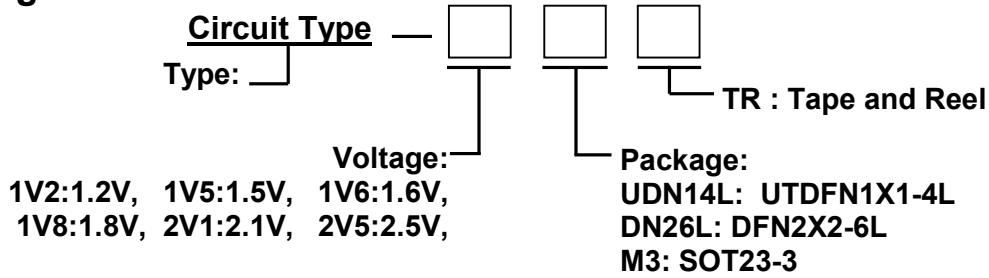
Figure 3. Fixed Vout LDO

Figure 4: Fixed Vout LDO with enable function
-Adjustable Vout Circuit with EN control function

Figure 5. Fixed Vout LDO with enable and sense functions
Function Block Diagram

Figure 6. Function Block Diagram

6V, 300mA, 2uA Low Iq, Low Dropout Voltage Linear Regulator
Ordering Information

Ordering Code

Part Number	Marking ID	Temperature Range	Package	Package Type
HCR2136-1V2UDN14LTR	HA	-40°C to +85°C	UTDFN1X1-4L	10000pcs/TR
HCR2136-1V5UDN14LTR	HB	-40°C to +85°C	UTDFN1X1-4L	10000pcs/TR
HCR2136-1V6UDN14LTR	HC	-40°C to +85°C	UTDFN1X1-4L	10000pcs/TR
HCR2136-1V8UDN14LTR	1W	-40°C to +85°C	UTDFN1X1-4L	10000pcs/TR
HCR2136-2V1UDN14LTR	3V	-40°C to +85°C	UTDFN1X1-4L	10000pcs/TR
HCR2136-2V5UDN14LTR	HE	-40°C to +85°C	UTDFN1X1-4L	10000pcs/TR
HCR2136-2V8UDN14LTR	HF	-40°C to +85°C	UTDFN1X1-4L	10000pcs/TR
HCR2136-3V0UDN14LTR	HJ	-40°C to +85°C	UTDFN1X1-4L	10000pcs/TR
HCR2136-3V3UDN14LTR	HK	-40°C to +85°C	UTDFN1X1-4L	10000pcs/TR
HCR2136-1V2DN26LTR	*A	-40°C to +85°C	DFN2X2-6L	3000pcs/TR
HCR2136-1V5DN26LTR	*B	-40°C to +85°C	DFN2X2-6L	3000pcs/TR
HCR2136-1V6DN26LTR	*C	-40°C to +85°C	DFN2X2-6L	3000pcs/TR
HCR2136-1V8DN26LTR	*D	-40°C to +85°C	DFN2X2-6L	3000pcs/TR
HCR2136-2V5DN26LTR	*E	-40°C to +85°C	DFN2X2-6L	3000pcs/TR
HCR2136-2V8DN26LTR	*F	-40°C to +85°C	DFN2X2-6L	3000pcs/TR
HCR2136-3V0DN26LTR	*J	-40°C to +85°C	DFN2X2-6L	3000pcs/TR
HCR2136-3V3DN26LTR	*H	-40°C to +85°C	DFN2X2-6L	3000pcs/TR
HCR2136-1V2M5TR	AADB	-40°C to +85°C	SOT-23-5	3000pcs/TR
HCR2136-1V5M5TR	AAC1	-40°C to +85°C	SOT-23-5	3000pcs/TR
HCR2136-1V6M5TR	AAC2	-40°C to +85°C	SOT-23-5	3000pcs/TR
HCR2136-1V8M5TR	AAC3	-40°C to +85°C	SOT-23-5	3000pcs/TR
HCR2136-2V5M5TR	AAC4	-40°C to +85°C	SOT-23-5	3000pcs/TR
HCR2136-2V8M5TR	90205	-40°C to +85°C	SOT-23-5	3000pcs/TR
HCR2136-3V0M5TR	AAC6	-40°C to +85°C	SOT-23-5	3000pcs/TR
HCR2136-3V3M5TR	AAC7	-40°C to +85°C	SOT-23-5	3000pcs/TR
HCR2136-1V2M3TR	AAS1	-40°C to +85°C	SOT23-3	3000pcs/TR
HCR2136-1V5M3TR	AAS2	-40°C to +85°C	SOT23-3	3000pcs/TR
HCR2136-1V6M3TR	AAS3	-40°C to +85°C	SOT23-3	3000pcs/TR
HCR2136-1V8M3TR	AAS4	-40°C to +85°C	SOT23-3	3000pcs/TR
HCR2136-2V5M3TR	AAS5	-40°C to +85°C	SOT23-3	3000pcs/TR
HCR2136-2V8M3TR	AAS6	-40°C to +85°C	SOT23-3	3000pcs/TR
HCR2136-3V0M3TR	AAS7	-40°C to +85°C	SOT23-3	3000pcs/TR
HCR2136-3V3M3TR	AAS8	-40°C to +85°C	SOT23-3	3000pcs/TR

6V, 300mA, 2uA Low Iq, Low Dropout Voltage Linear Regulator
Absolute Maximum Ratings ^{Note 1}

Parameter	Symbol	Value	Unit	
Supply Voltage VIN Pin	VIN	-0.3 to 6.5	V	
Supply Voltage VOUT, EN Pin to GND	VOUT, VEN	-0.3 to 6.0	V	
Output Voltage VOUT to VIN	VOUT	-6 to 0.3	V	
Thermal Resistance Junction to Ambient @TA=+25°C note 2	SOT-23-5	θJA	200	'C/W
	SOT23-3	θJA	215	'C/W
	UTDFN 1X1-4L	θJA	195	'C/W
	DFN2X2-6L	θJA	95	'C/W
Thermal Resistance Junction to Case @TA=+25°C	SOT-23-5	θJC	90	'C/W
	SOT23-3	θJC	95	'C/W
	UTDFN 1X1-4L	θJC	60	'C/W
	DFN2X2-6L	θJC	28	'C/W
Storage Temperature Range	TSTG	-60 to +150	'C	
Operating Temperature Range	TOPR	-40 to +85	'C	
Junction Temperature	TJ	+150	'C	
Lead Temperature (Soldering, 10s)	TLEAD	260	'C	
Human Body Model ESD Protection	ESD HBM	2000	V	
Machine Model ESD Protection	ESD MM	200	V	

Note 1: Stresses above those listed under "Maximum Ratings" may cause permanent damage to the device.

This is a stress rating only and functional operation of the device at those or any other conditions above those indicated in the operational listings of this specification is not implied. Exposure to maximum rating conditions for extended periods may affect device reliability.

2: θJA is measured at TA=25°C on a Star-wing EVB board

Recommended Operating Conditions

Parameter	Symbol	Min.	Max.	Unit
Operating Voltage Range	VIN	1.2	5.5	V
Junction Temperature Range	Tc	-40	+125	'C
Operating Temperature Range	TA	-40	+85	'C

6V, 300mA, 2uA Low Iq, Low Dropout Voltage Linear Regulator
Electrical Characteristics

(at TA=25 °C, VIN=5V, VEN=5V, unless otherwise noted.)

Parameter	Symbol	Conditions	Min	Type	Max	Unit	
Input Voltage Range	VIN		1.2	-	5.5	V	
VOUT Voltage Accuracy	RACC	IOUT=0.1mA	-2	-	+2	%	
SNS Input Current	ISNS	SNS=VOUT	-	0.5	-	uA	
Dropout Voltage note 3	VDROP_3V	IOUT=300mA, VOUT>=3V	-	0.18	-	V	
	VDROP_2.8V	IOUT=300mA, VOUT=2.8V	-	0.23	-	V	
	VDROP_2.5V	IOUT=300mA, VOUT=2.5V	-	0.23	-	V	
	VDROP_1.8V	IOUT=300mA, VOUT=1.8V	-	0.28	-	V	
	VDROP_1.5V	IOUT=300mA, VOUT=1.5V	-	0.36	-	V	
	VDROP_1.2V	IOUT=300mA, VOUT=1.2V	-	0.45	-	V	
Ground Current	IQ	ILOAD=0mA	-	2	-	uA	
Shutdown Ground Current	ISD	VEN=0V, VOUT=0V	-	0.1	0.5	uA	
VOUT Shutdown Leakage Current	I _{LEAK}		-	0.1	0.5		
Enable Threshold Voltage	VENL	EN Falling	-	-	0.4	V	
	VENH	EN Rising	1.0	-	-	V	
EN Input Current	IEN	VEN=5V	-	10	100	nA	
Continuous Output Current	Io	-	-	-	300	mA	
Output Current Limit	ILIM	VOUT=0V	301	600	-	mA	
Line Regulation	ΔLINE	ILOAD=30mA, 1.5V<=VIN<=5.5V or (VOUT+0.2V)<=VIN<=5.5V	-	0.2	-	%	
Load Regulation	ΔLOAD	10mA<=IOUT<=300mA	-	0.2	-	%	
Power Supply Rejection Ratio	PSRR	VOUT=1.2V, VIN=2V, IOUT=5mA	f=100Hz	-	80	-	dB
			f=1KHz	-	75	-	
Output Voltage Noise(10Hz to 100KHz)	VNOISE	VIN=3.5V, ILOAD=0.1A	VOUT=1.2V	-	80	-	uVRMS
			VOUT=2.8V	-	120	-	
Thermal Shutdown Temperature	TSD	ILOAD=10mA	-	155	-	°C	
Thermal Shutdown Temperature	ΔTSD		-	15	-	°C	
Discharge Resistance		EN=0V, VOUT=0.1V	-	100	-	Ω	

Note3: VDROP=VIN-VOUT when the VOUT is 98% of its target value.

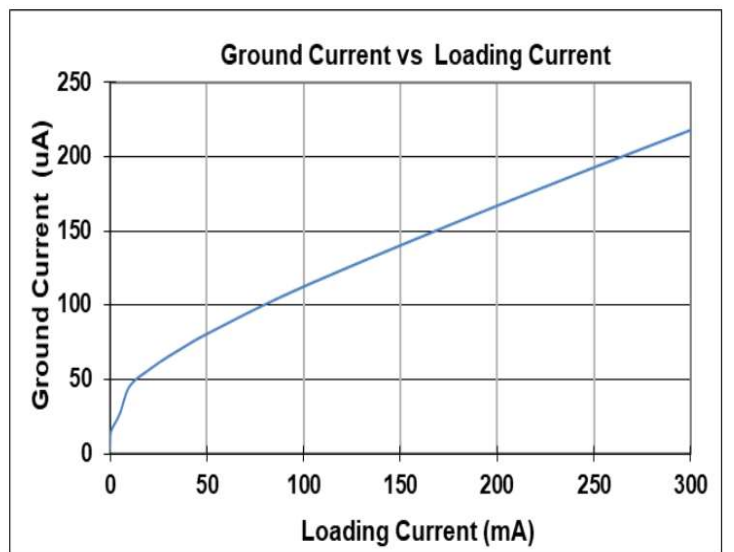
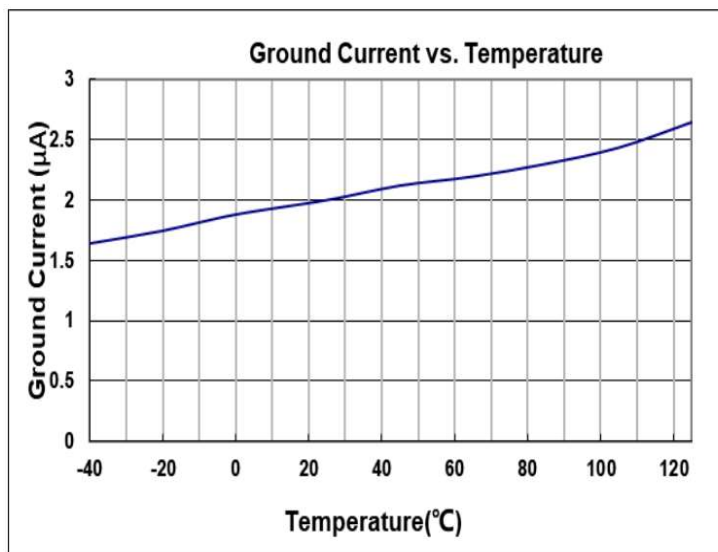
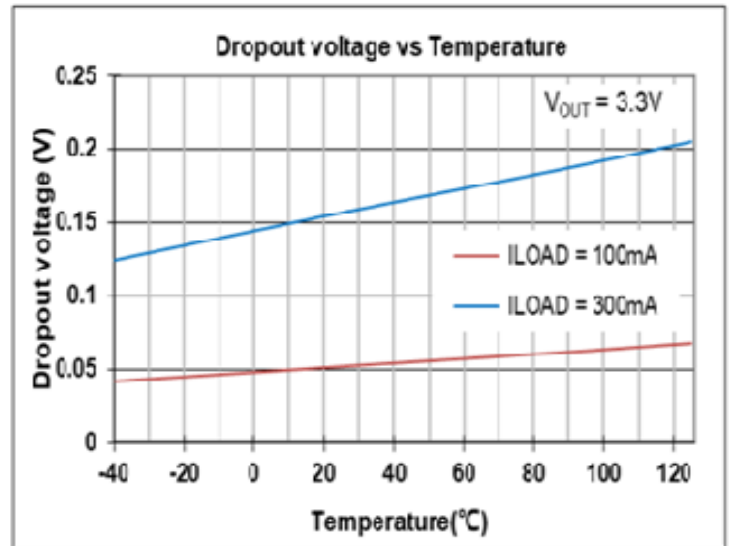
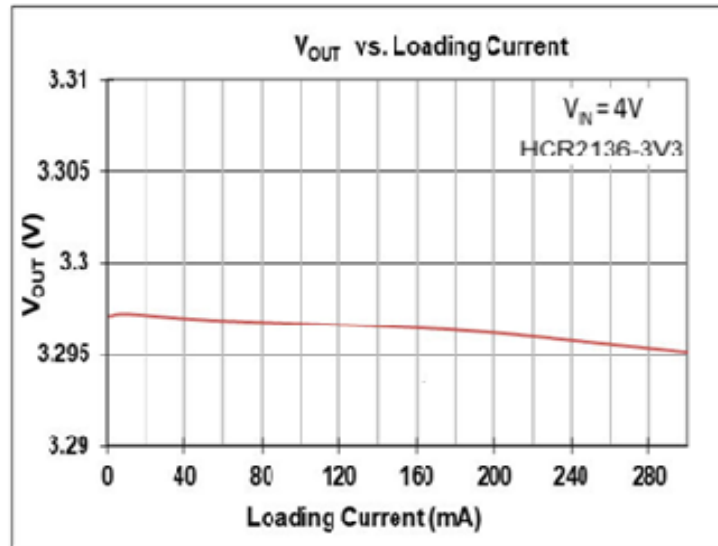
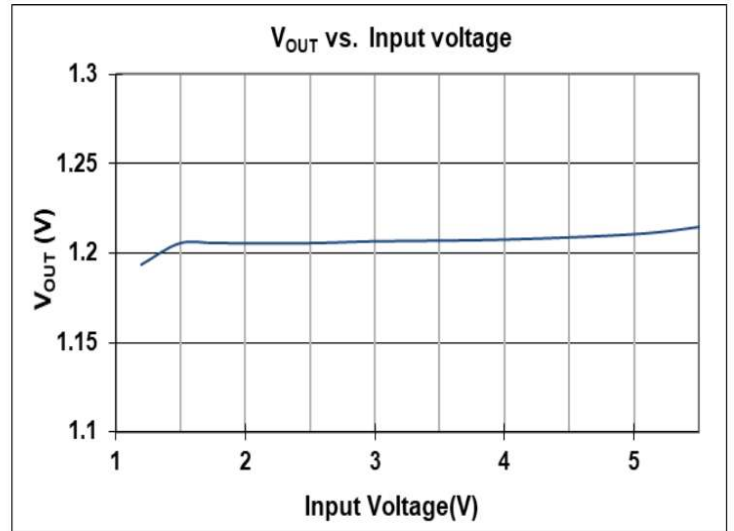
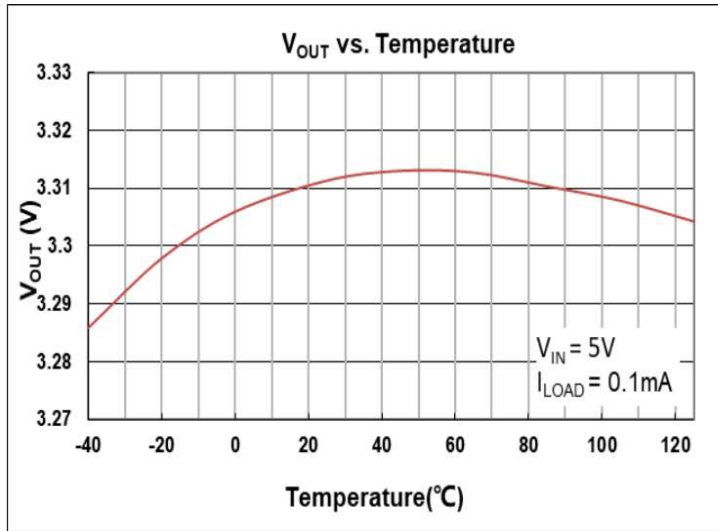
6V, 300mA, 2uA Low Iq, Low Dropout Voltage Linear Regulator
Typical Performance Characteristics (Unless Otherwise Specified.)

6V, 300mA, 2uA Low Iq, Low Dropout Voltage Linear Regulator

Typical Performance Characteristics (continued)

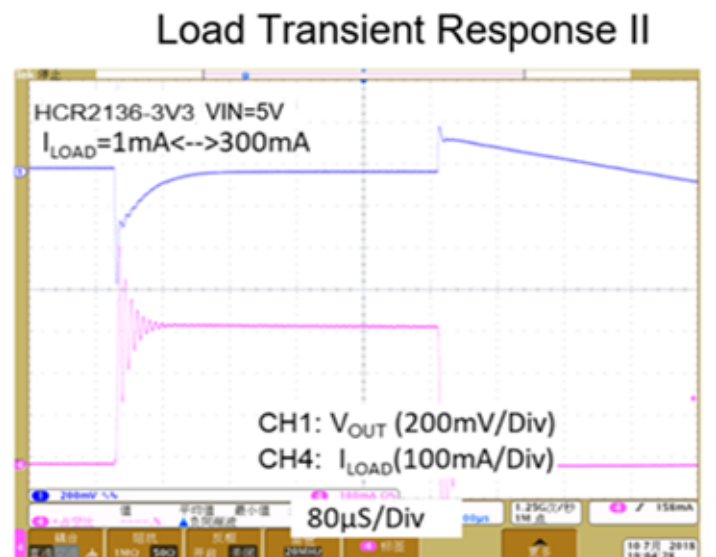
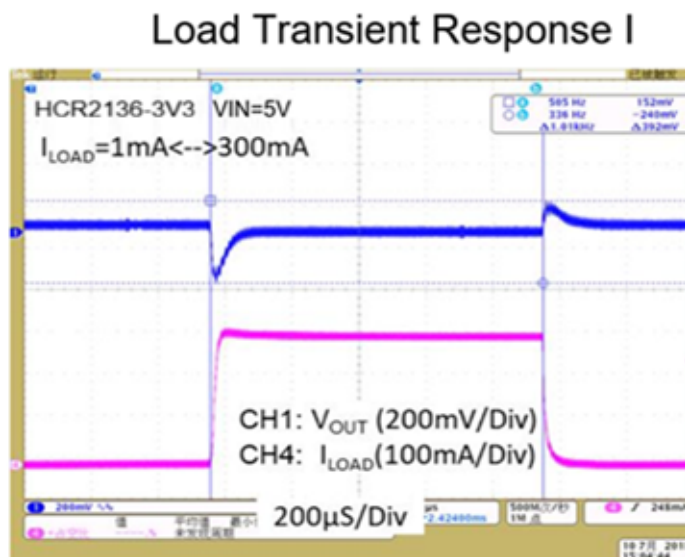
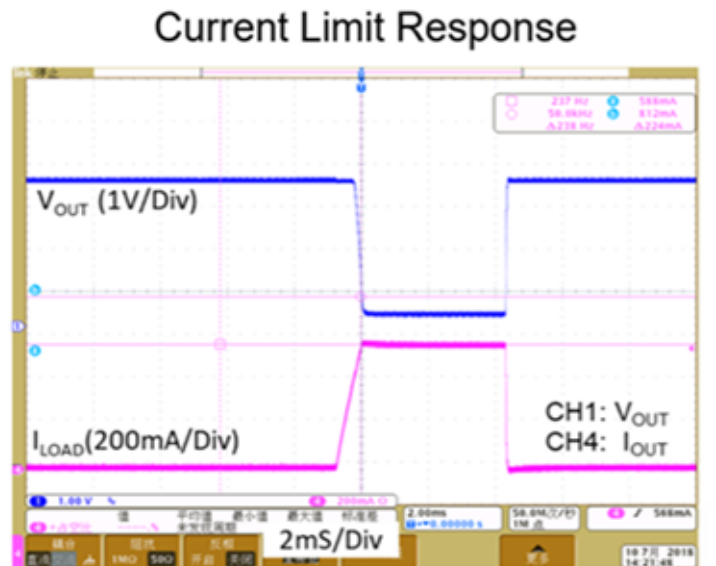
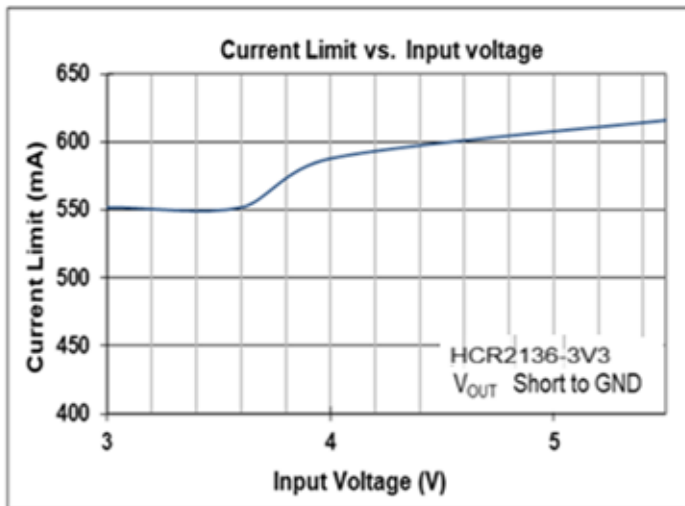
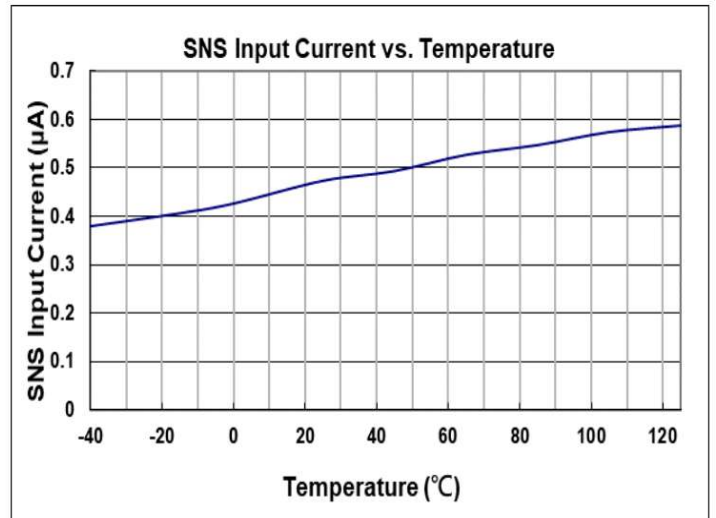
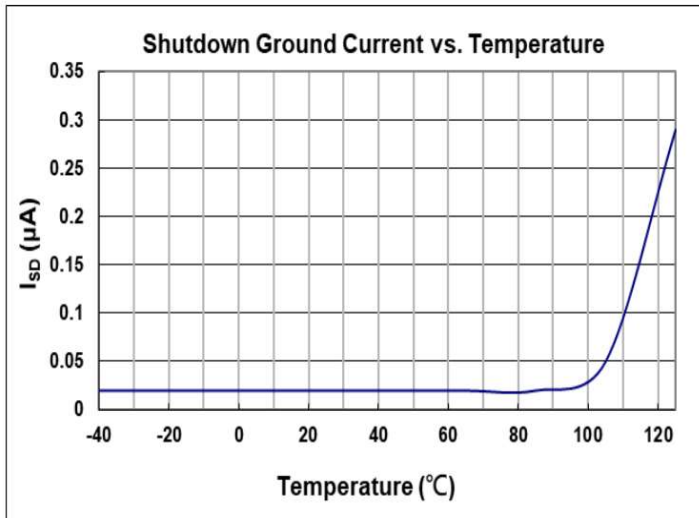

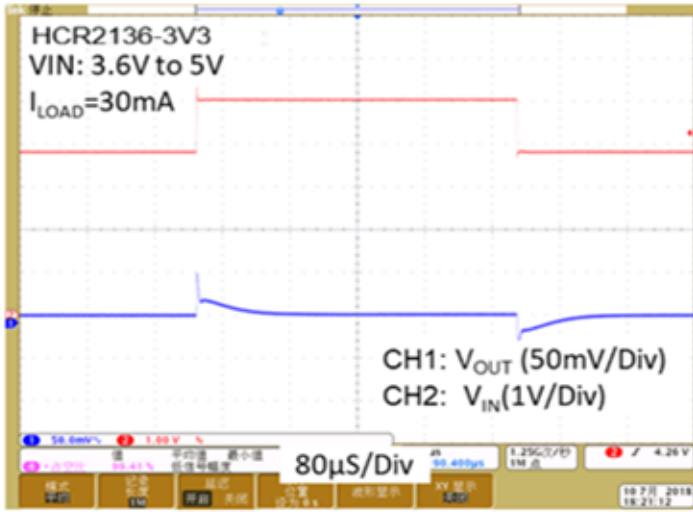
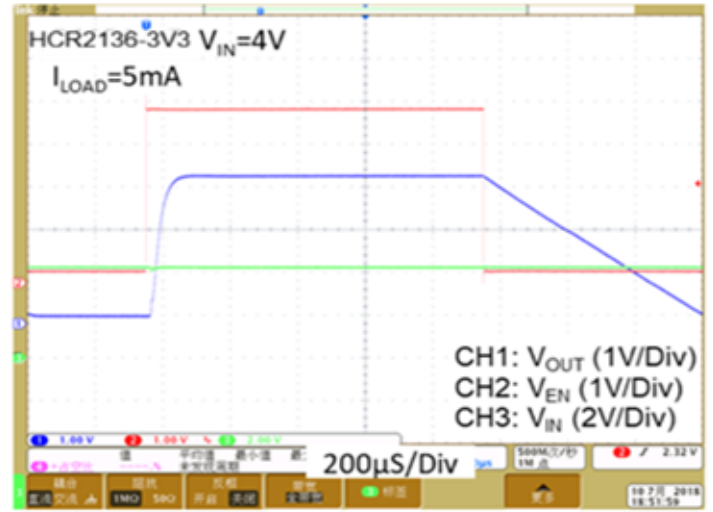
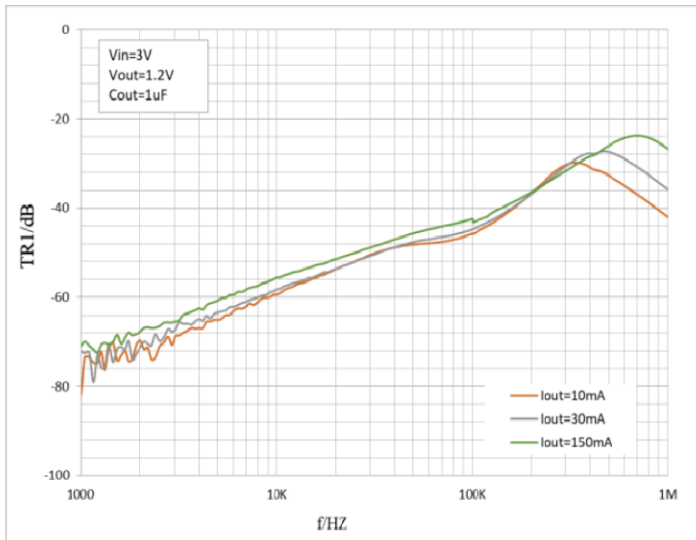
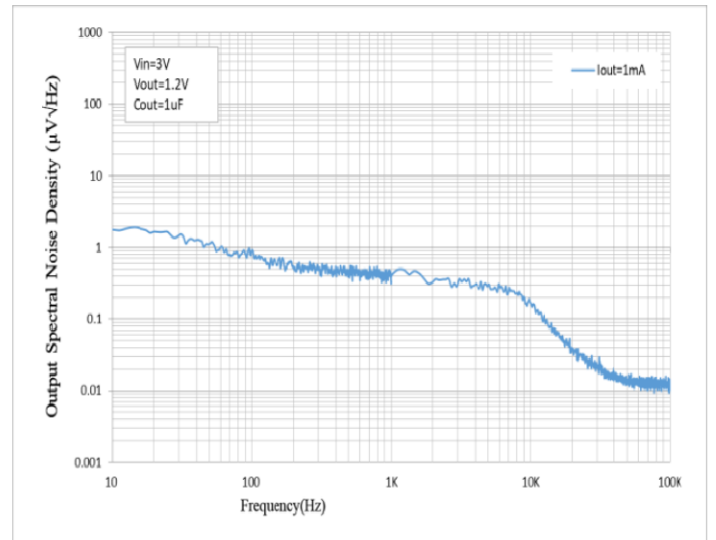
6V, 300mA, 2uA Low Iq, Low Dropout Voltage Linear Regulator
Typical Performance Characteristics (continued)
Line Transient Response

V_{OUT} Turn On/Off by EN

PSRR vs. Frequency

Noise Density Spectrum

6V, 300mA, 2uA Low Iq, Low Dropout Voltage Linear Regulator

Application Guideline

Input and Output Capacitor Requirements

The external input and output capacitors of HCR2136 series must be properly selected for stability and performance. Use a 1μF or larger input capacitor and place it close to the IC's VIN and GND pins. Any output capacitor meeting the minimum 1mΩ ESR (Equivalent Series Resistance) and effective capacitance between 1μF and 22μF requirement may be used. Place the output capacitor close to the IC's VOUT and GND pins. Increasing capacitance and decreasing ESR can improve the circuit's PSRR and line transient response.

Current Limit

The HCR2136 series contain the current limiter of output power transistor, which monitors and controls the transistor, limiting the output current to 600mA (typical). The output can be shorted to ground indefinitely without damaging the part.

Dropout Voltage

The HCR2316 series use a PMOS pass transistor to achieve low dropout. When (VIN – VOUT) is less than the dropout voltage (VDROP), the PMOS pass device is in the linear region of operation and the input-to-output resistance is the RDS(ON) of the PMOS pass element. VDROP scales approximately with the output current because the PMOS device behaves as a resistor in dropout condition.

As any linear regulator, PSRR and transient response are degraded as (VIN – VOUT) approaches dropout condition.

Adjustable Output Voltage Application

The HCR2136 by SNS pin also can work as an adjustable output voltage LDO. Figure 3 gives the connections for the adjustable output voltage application. The resistor divider from VOUT to SNS sets the output voltage when in regulation.

The voltage on the SNS pin sets the output voltage and is determined by the values of R1 and R2. To keep a good temperature coefficient of output voltage, the values of R1 and R2 should be selected carefully to ignore the temperature effect of input current at the SNS pin. A current greater than 50μA in the resistor divider is recommended to meet the above requirement.

The adjustable output voltage can be calculated using the formula given in equation 1:

$$V_{OUT} = \frac{R1+R2}{R2} \times V_{SNS} \quad (1)$$

where VSNS is determined by the output voltage selections in the ordering information of HCR2136-1V2. The minimum recommended 50μA in the resistor divider makes the application no longer a 2μA low quiescent LDO.

OTP (Over Temperature Protection)

The over temperature protection function of HCR2136 series will turn off the P-MOSFET when the junction temperature exceeds 155°C (typ.). Once the junction temperature cools down by approximately 15°C, the regulator will automatically resume operation.

6V, 300mA, 2uA Low Iq, Low Dropout Voltage Linear Regulator

Application Guideline(con.)

Thermal Application

For continuous operation, do not exceed the absolute maximum junction temperature. The maximum power dissipation depends on the thermal resistance of the IC package, PCB layout, rate of surrounding airflow, and difference between junction and ambient temperature.

The maximum power dissipation can be calculated as below:

$T_A=25^{\circ}\text{C}$, HCR-Tech PCB

The max PD(Max) = $(125^{\circ}\text{C} - 25^{\circ}\text{C}) / (200^{\circ}\text{C}/\text{W}) = 0.5\text{W}$ for SOT-23-5 packages.

The max PD (Max) = $(125^{\circ}\text{C} - 25^{\circ}\text{C}) / (195^{\circ}\text{C}/\text{W}) = 0.51\text{W}$ for UTDFN1x1-4L package.

The max PD (Max) = $(125^{\circ}\text{C} - 25^{\circ}\text{C}) / (95^{\circ}\text{C}/\text{W}) = 1.05\text{W}$ for DFN2x2-6L package.

Power dissipation (PD) is equal to the product of the output current and the voltage drop across the output pass element, as shown in the equation below:

$$\text{PD} = (\text{VIN} - \text{VOUT}) \times \text{IOUT}$$

Layout Consideration

By placing input and output capacitors on the same side of the PCB as the LDO, and placing them as close as is practical to the package can achieve the best performance. The ground connections for input and output capacitors must be back to the HCR2136 ground pin using as wide and as short of a copper trace as is practical.

Connections using long trace lengths, narrow trace widths, and/or connections through via must be avoided. These add parasitic inductances and resistance that results in worse performance especially during transient conditions.

Mechanical Dimensions
PKG: UTDFN1X1-4L (UDN14L)

Unit: mm

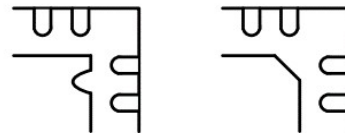
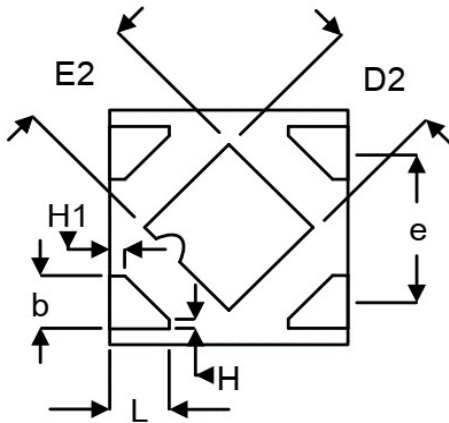
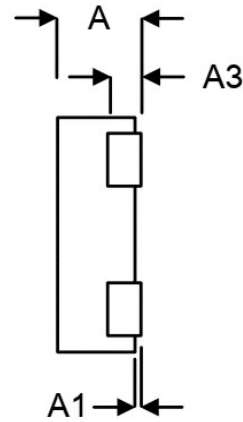
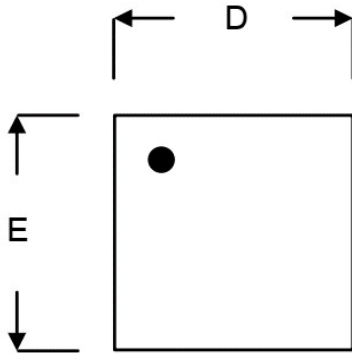
DETAILA

PIN #1 ID and Tie Bar Mark Options

Note : The configuration of the Pin #1 identifier is optional, but must be located within the zone indicated.

Symbol	Millimeters		Inches	
	Min.	Max.	Min.	Max.
A	0.300	0.400	0.012	0.016
A1	0.000	0.050	0.000	0.002
A3	0.117	0.162	0.005	0.006
b	0.175	0.280	0.007	0.011
D	0.900	1.100	0.035	0.043
D2	0.430	0.550	0.017	0.022
E	0.900	1.100	0.035	0.043
E2	0.430	0.550	0.017	0.022
e	0.650		0.026	
L	0.200	0.300	0.008	0.012
H	0.039		0.002	
H1	0.064		0.003	

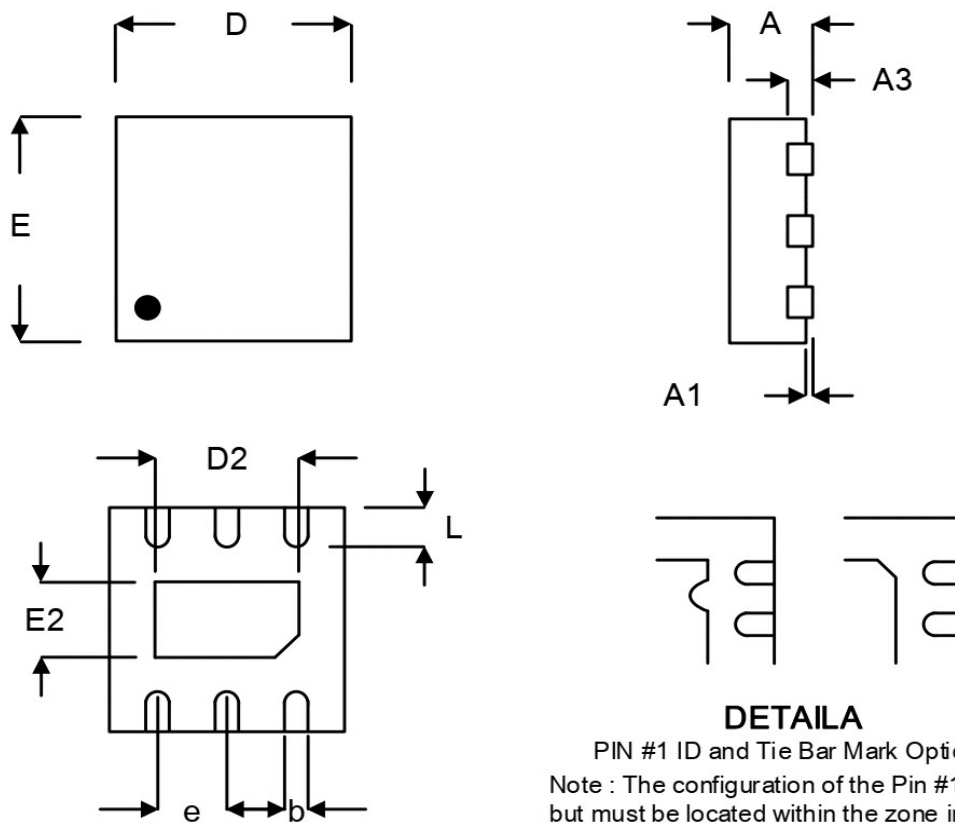
6V, 300mA, 2uA Low Iq, Low Dropout Voltage Linear Regulator
Mechanical Dimensions (Con.)
PKG: DFN2X2-6L (DN26L)
Unit: mm

DETAILA

PIN #1 ID and Tie Bar Mark Options

Note : The configuration of the Pin #1 identifier is optional, but must be located within the zone indicated.

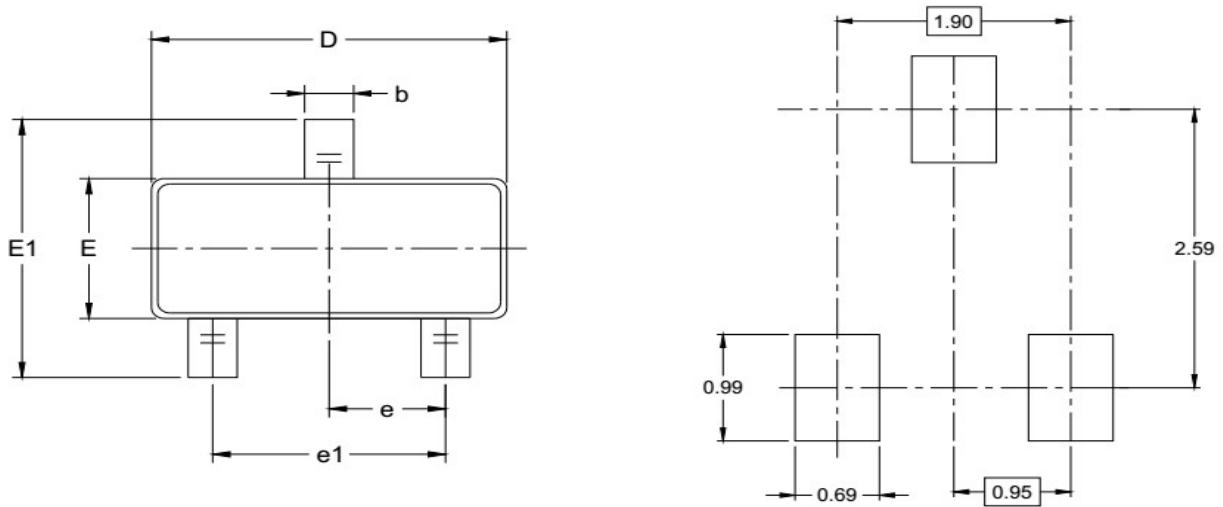
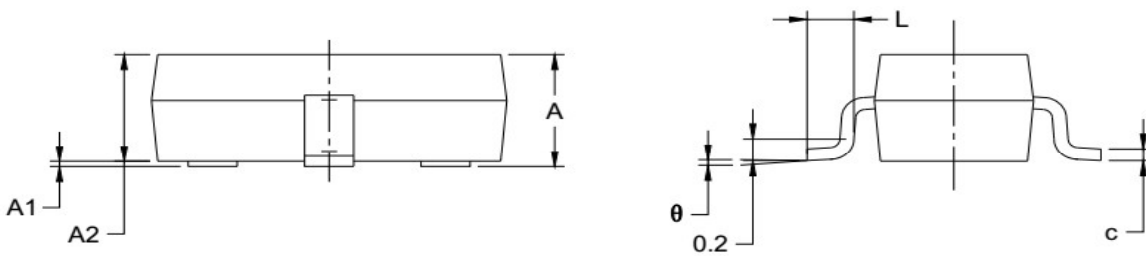
Symbol	Millimeters		Inches	
	Min.	Max.	Min.	Max.
A	0.700	0.800	0.028	0.031
A1	0.000	0.050	0.000	0.002
A3	0.175	0.250	0.007	0.010
b	0.200	0.350	0.008	0.014
D	1.950	2.050	0.077	0.081
D2	1.000	1.450	0.039	0.057
E	1.950	2.050	0.077	0.081
E2	0.500	0.850	0.020	0.033
e	0.650		0.026	
L	0.300	0.400	0.012	0.016

6V, 300mA, 2uA Low Iq, Low Dropout Voltage Linear Regulator
Mechanical Dimensions (Con.)
PKG:SOT23-3 (M3)
Unit: mm (inch)

RECOMMENDED LAND PATTERN (Unit: mm)

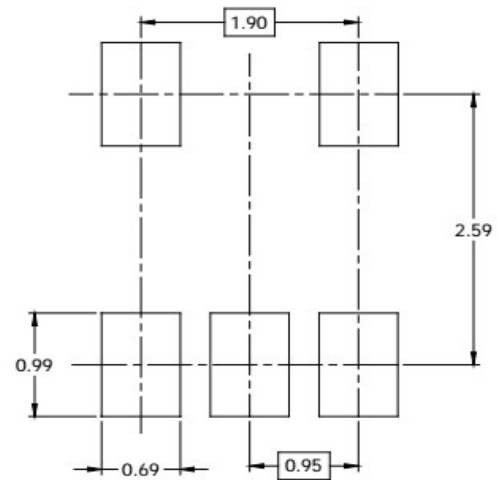
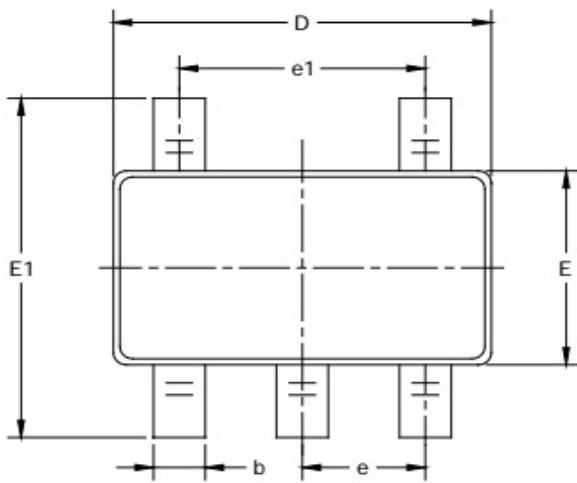
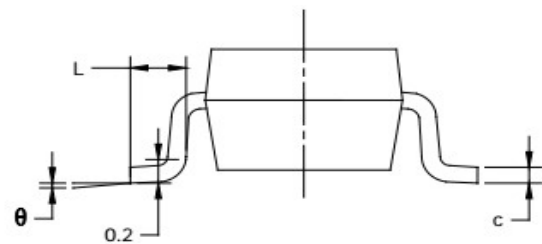
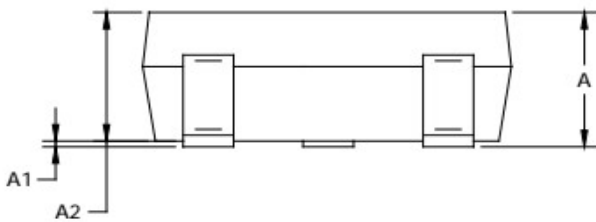
Symbol	Dimensions In Millimeters		Dimensions In Inches	
	MIN	MAX	MIN	MAX
A	1.050	1.250	0.041	0.049
A1	0.000	0.100	0.000	0.004
A2	1.050	1.150	0.041	0.045
b	0.300	0.500	0.012	0.020
c	0.100	0.200	0.004	0.008
D	2.820	3.020	0.111	0.119
E	1.500	1.700	0.059	0.067
E1	2.650	2.950	0.104	0.116
e	0.950 BSC		0.037 BSC	
e1	1.900 BSC		0.075 BSC	
L	0.300	0.600	0.012	0.024
θ	0°	8°	0°	8°

6V, 300mA, 2uA Low Iq, Low Dropout Voltage Linear Regulator
Mechanical Dimensions (Con.)
PKG:SOT-23-5 (M5)
Unit: mm (inch)

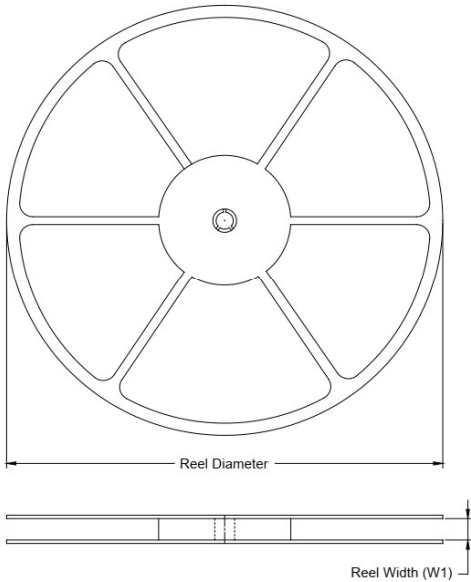
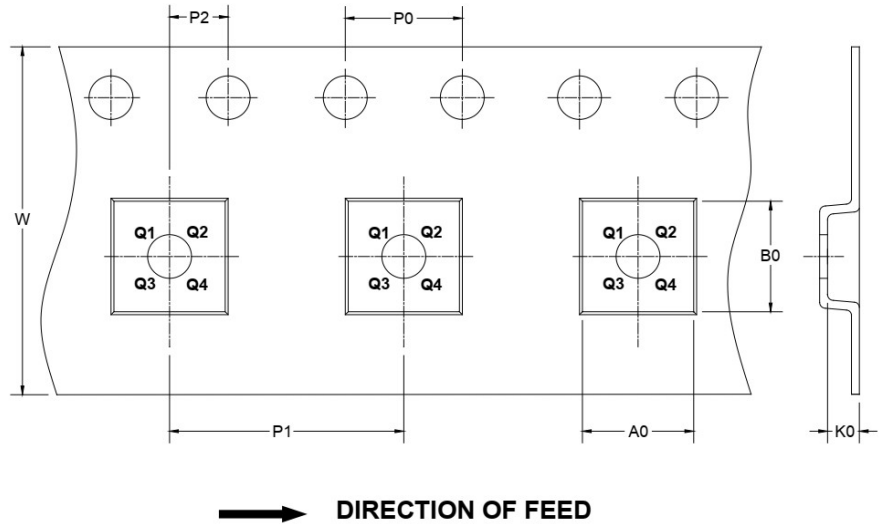
RECOMMENDED LAND PATTERN (Unit: mm)

Symbol	Dimensions In Millimeters		Dimensions In Inches	
	MIN	MAX	MIN	MAX
A	1.050	1.250	0.041	0.049
A1	0.000	0.100	0.000	0.004
A2	1.050	1.150	0.041	0.045
b	0.300	0.500	0.012	0.020
c	0.100	0.200	0.004	0.008
D	2.820	3.020	0.111	0.119
E	1.500	1.700	0.059	0.067
E1	2.650	2.950	0.104	0.116
e	0.950 BSC		0.037 BSC	
e1	1.900 BSC		0.075 BSC	
L	0.300	0.600	0.012	0.024
θ	0°	8°	0°	8°

6V, 300mA, 2uA Low Iq, Low Dropout Voltage Linear Regulator
TAPE AND REEL INFORMATION
REEL DIMENSIONS

TAPE DIMENSIONS

NOTE: The picture is only for reference. Please make the object as the standard.

KEY PARAMETER LIST OF TAPE AND REEL

Package Type	Reel Diameter	Reel Width W1 (mm)	A0 (mm)	B0 (mm)	K0 (mm)	P0 (mm)	P1 (mm)	P2 (mm)	W (mm)	Pin1 Quadrant
SOT-23-5	7"	9.5	3.20	3.20	1.40	4.0	4.0	2.0	8.0	Q3
SOT23-3	7"	9.5	3.20	3.20	1.40	4.0	4.0	2.0	8.0	Q3
UTDFN-1x1-4L	7"	9.0	1.20	1.20	0.60	4.0	2.0	2.0	8.0	Q1
DFN-2x2-4L	7"	9.5	2.25	2.55	1.20	4.0	4.0	2.0	8.0	Q1

6V, 300mA, 2uA Low Iq, Low Dropout Voltage Linear Regulator

Conditions of Soldering and Storage

• Recommended condition of reflow soldering

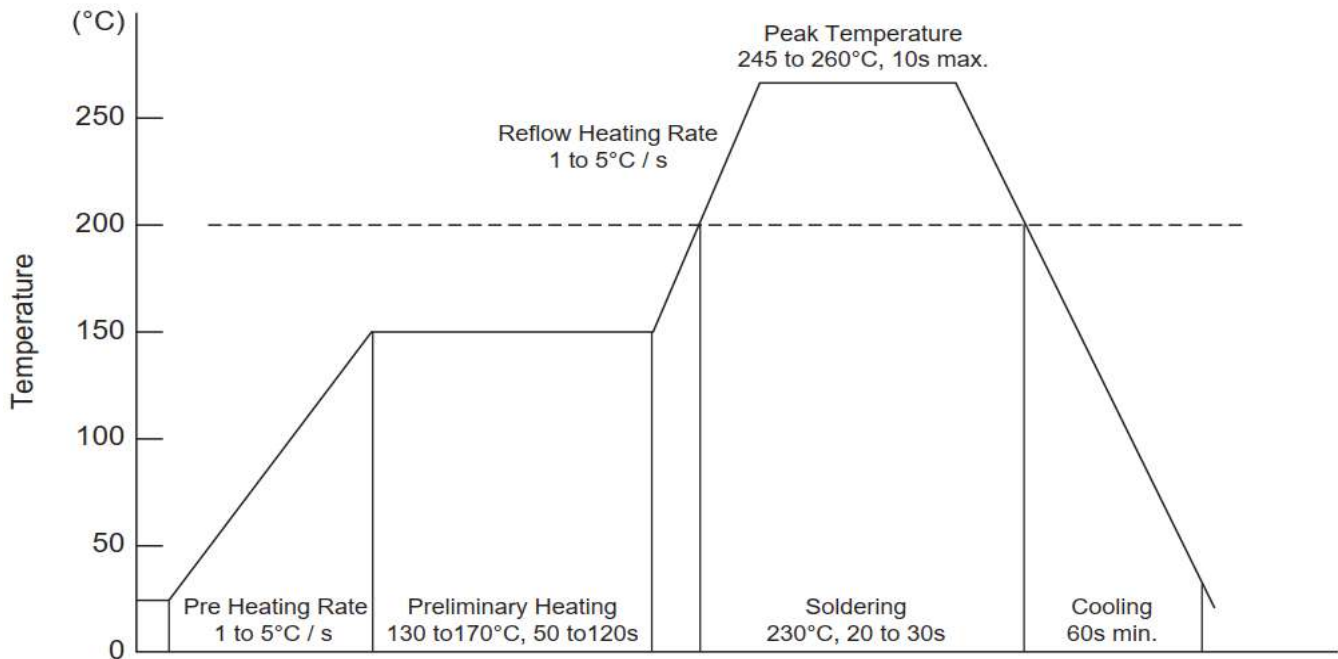

Recommended peak temperature is over 245°C, if peak temperature is below 245°C, you may adjust the following parameters:

- * Time length of peak temperature (longer)
- * Time length of soldering (longer)
- * Thickness of solder paste (thicker)

• Conditions of hand soldering

- * Temperature : 300°C
- * Time : 3s max
- * Times : one time

• Storage conditions

- * Temperature
5 to 40°C
- * Humidity
30 to 80% RH
- * Recommended period
One year after manufacturing