

## 7.5V, 500mA Low Power, Low Dropout and RF-Linear Regulators

### Features

- 500mA Guaranteed Output Current
- 1.7V to 7.5V Input Voltage Range
- 30 $\mu$ A(TYP) Low Supply Current
- 10nA Logic-Controlled Shutdown
- Output Current Limit
- Low Output Noise
- Low Dropout Voltage
- Thermal-Overload Protection
- -40°C to +85°C Operating Temperature Range

### Applications

- Cellular Telephones
- Camera Modules & Modems
- HiFi Audio Radio Transceivers
- PLL/Synthesizer, Clocking
- Medium-Current, Noise-Sensitive Applications

### General Description

The HCR2138 series low-power, low-dropout, CMOS LDO operate from 1.7V to 7.5V input voltage that can supply up to 500mA of output current. Designed to meet the requirements of RF and analog circuits, the HCR2138 series device provides low noise, high PSRR, low quiescent current and low line and load transient response.

The device is designed to work with a 1 $\mu$ F input and a 1 $\mu$ F output ceramic capacitor ( no separate noise bypass capacitor required ). An external noise bypass capacitor connected to the device's BP pin can further reduce the noise level.

Other features include a 10nA logic-controlled shutdown mode, foldback current limit and thermal shutdown protection.

The HCR2138 series is available in Green UTDFN-1x1-4L, SOT23-3 and SOT23-5 package. It operates over an ambient temperature range of -40°C to +85°C

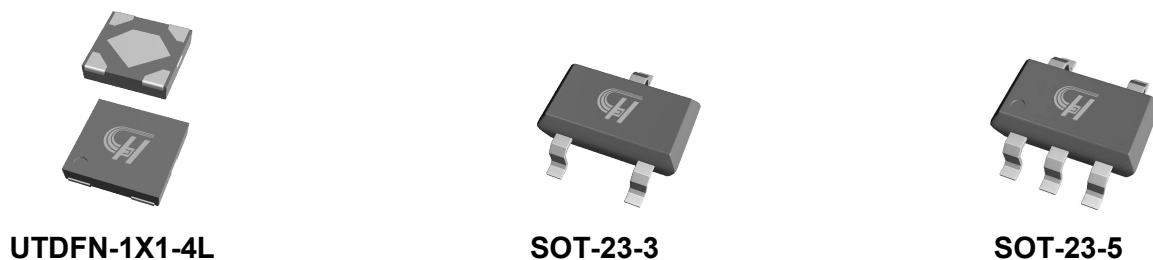

Figure 1. Package Type of HCR2138

**7.5V, 500mA Low Power, Low Dropout and RF-Linear Regulators**
**Pin Configuration**

Figure 2. Pin Configuration of HCR2138 (Top View )

**Pin Function Table**

Pin Function				Function
SOT-23-5	SOT-23-3	UTDFN-1X1-4L	Name	
1	3	4	VIN	Regulator Input. Supply voltage can range from 1.7V to 7.5V. Bypass with a 1uF capacitor to GND.
2	1	2	GND	Ground
3	-	3	EN	Enable Input. A logic low reduces the supply current to 10nA. Connect to IN for normal operation.
4	-	-	BP/NC	NC or connect 0.01uF ceramic capacitor for reduced noise at the output.
5	2	-	FB	Feedback Pin (adjustable voltage version only). This is used to set the output voltage of the device.
5	2	1	VOUT	Regulator Output
-	-	Thermal Pad	-	Connect the thermal pad to a large-area ground plane. This pad is not an electrical connection to the device ground.

**Functional Diagrams**

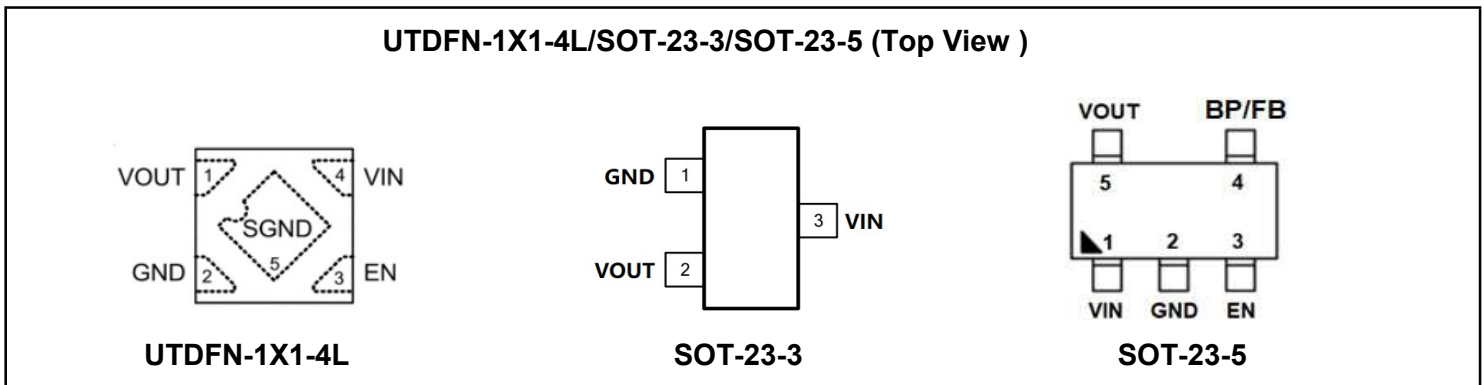
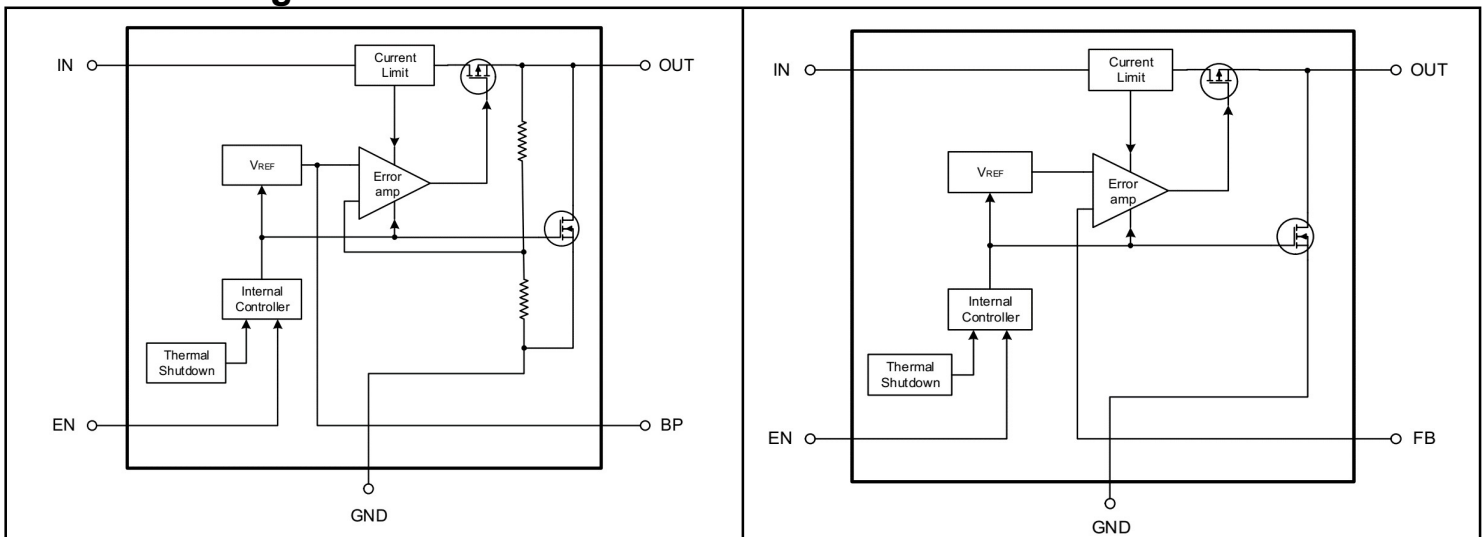
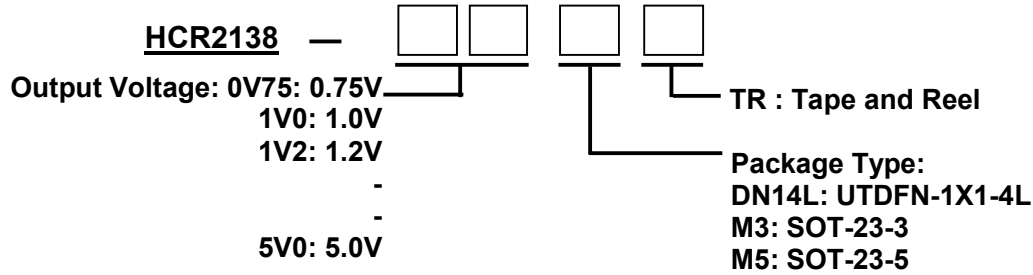
**7.5V, 500mA Low Power, Low Dropout and RF-Linear Regulators**
**Ordering Information**

**Ordering Code**

Part Number	VOUT(V)	Package	Marking	Package Type
HCR2138-0V75DN14LTR	0.75V	UTDFN-1X1-4L	BA	10000pcs/TR
HCR2138-0V75M3TR	0.75V	SOT-23-3	LB075	3000pcs/TR
HCR2138-0V75M5TR	0.75V	SOT-23-5	LB075	3000pcs/TR
HCR2138-1V0DN14LTR	1.0V	UTDFN-1X1-4L	BB	10000pcs/TR
HCR2138-1V0M3TR	1.0V	SOT-23-3	LB10	3000pcs/TR
HCR2138-1V0M5TR	1.0V	SOT-23-5	LB10	3000pcs/TR
HCR2138-1V2DN14LTR	1.2V	UTDFN-1X1-4L	BC	10000pcs/TR
HCR2138-1V2M3TR	1.2V	SOT-23-3	LB12	3000pcs/TR
HCR2138-1V2M5TR	1.2V	SOT-23-5	LB12	3000pcs/TR
HCR2138-1V5DN14LTR	1.5V	UTDFN-1X1-4L	BD	10000pcs/TR
HCR2138-1V5M3TR	1.5V	SOT-23-3	LB15	3000pcs/TR
HCR2138-1V5M5TR	1.5V	SOT-23-5	LB15	3000pcs/TR
HCR2138-1V8DN14LTR	1.8V	UTDFN-1X1-4L	BE	10000pcs/TR
HCR2138-1V8M3TR	1.8V	SOT-23-3	LB18	3000pcs/TR
HCR2138-1V8M5TR	1.8V	SOT-23-5	LB18	3000pcs/TR
HCR2138-2V1M5TR	2.1V	SOT-23-5	LB21	3000pcs/TR
HCR2138-2V5DN14LTR	2.5V	UTDFN-1X1-4L	BG	10000pcs/TR
HCR2138-2V5M3TR	2.5V	SOT-23-3	LB25	3000pcs/TR
HCR2138-2V5M5TR	2.5V	SOT-23-5	LB25	3000pcs/TR
HCR2138-2V7M5TR	2.7V	SOT-23-5	LB27	3000pcs/TR
HCR2138-2V8DN14LTR	2.8V	UTDFN-1X1-4L	BH	10000pcs/TR
HCR2138-2V8M3TR	2.8V	SOT-23-3	LB28	3000pcs/TR
HCR2138-2V8M5TR	2.8V	SOT-23-5	LB28	3000pcs/TR
HCR2138-3V0DN14LTR	3.0V	UTDFN-1X1-4L	BI	10000pcs/TR
HCR2138-3V0M3TR	3.0V	SOT-23-3	LB30	3000pcs/TR
HCR2138-3V0M5TR	3.0V	SOT-23-5	LB30	3000pcs/TR
HCR2138-3V3DN14LTR	3.3V	UTDFN-1X1-4L	BJ	10000pcs/TR
HCR2138-3V3M3TR	3.3V	SOT-23-3	LB33	3000pcs/TR
HCR2138-3V3M5TR	3.3V	SOT-23-5	LB33	3000pcs/TR
HCR2138-3V6DN14LTR	3.6V	UTDFN-1X1-4L	BK	10000pcs/TR
HCR2138-3V6M3TR	3.6V	SOT-23-3	LB36	3000pcs/TR
HCR2138-3V6M5TR	3.6V	SOT-23-5	LB36	3000pcs/TR

**7.5V, 500mA Low Power, Low Dropout and RF-Linear Regulators**
**Ordering Code(Con.)**

Part Number	VOUT(V)	Package	Marking	Package Type
HCR2138-4V0DN14LTR	4.0V	UTDFN-1X1-4L	BL	10000pcs/TR
HCR2138-4V0M3TR	4.0V	SOT-23-3	LB40	3000pcs/TR
HCR2138-4V0M5TR	4.0V	SOT-23-5	LB40	3000pcs/TR
HCR2138-5V0DN14LTR	5.0V	UTDFN-1X1-4L	BM	10000pcs/TR
HCR2138-5V0M3TR	5.0V	SOT-23-3	LB50	3000pcs/TR
HCR2138-5V0M5TR	5.0V	SOT-23-5	LB50	3000pcs/TR
HCR2138-ADJM5TR	ADJV	SOT-23-5	LBAD8	3000pcs/TR

**Absolute Maximum Ratings** Note 1, 2

Parameter	Symbol	Value	Unit
Supply Voltage, IN to GND	VIN	-0.3 to 8	V
Enable Input Voltage	VEN	-0.3 to VIN	V
Junction Temperature	TJ	150	'C
Power Dissipation at TA=25'C <small>note 3</small>	PD	Internally Limited	W
Storage Temperature Range	TSTG	-65 to 150	'C
Operating Temperature Range	TOPG	-25 to +85	'C
Lead Temperature (Soldering, 10s)	TLEAD	260	'C
Human Body Model ESD Protection	ESD HBM	±6000	V
Machine Model ESD Protection	ESD MM	±400	V

Note 1: Stresses beyond those listed under Absolute Maximum Ratings may cause permanent damage to the device. These are stress ratings only, and functional operation of the device at these or any other conditions beyond those indicated under Recommended Operating Conditions is not implied. Exposure to absolute-maximum-rated conditions for extended periods may affect device reliability.

2. All voltages are with respect to the GND pin.

3. Internal thermal shutdown circuitry protects the device from permanent damage.

**Recommended Operating Conditions**

Parameter	Symbol	Min.	Max.	Unit
Input Supply Voltage Range	VIN	1.7	7.5	V
Enable Input Voltage	VEN	0	VIN	V
Output Current	IOUT	0	500	mA
Operating Temperature Range	TA	-40	+85	'C

**Thermal Information**

Thermal Metric	Symbol	UTDFN-1X1-4L	SOT-23-3	SOT-23-5	Unit
Junction-to-ambient thermal resistance	R <sub>θJA</sub>	312.5	312.5	250	'C/W
Junction-to-ambient thermal resistance	R <sub>θJC</sub>	137.9	134.3	84.3	'C/W
Power Dissipation	P <sub>d</sub>	0.4	0.4	0.5	W

**7.5V, 500mA Low Power, Low Dropout and RF-Linear Regulators**
**Electrical Characteristics**

(VIN=VOUT(NOMINAL)+0.5V <sup>(1)</sup>, Full=-40°C to +85°C, unless otherwise noted.)

Parameter	Symbol	Conditions	TEMP	Min	Type	Max	Unit	
Input Voltage	VIN		+25°C	1.7	-	7.5	V	
Output Voltage Accuracy		IOUT=0.1mA	+25°C	-2.5	-	+2.5	%	
Feedback Voltage	VFB	IOUT=0.1mA	+25°C	0.79	0.81	0.83	V	
Max. Output Current <sup>note2</sup>	IOUT	VIN-VOUT=0.5V	+25°C	500	-	-	mA	
Current Limit	ILIM	-	+25°C	500	800	-	mA	
Ground Pin Current	Iq	No load	+25°C	-	30	40	uA	
Dropout Voltage <sup>(2)</sup>	VDROP	IOUT=500mA	+25°C	VOUT=1.2V	-	900	-	mV
				VOUT=1.5V	-	630	-	
				VOUT=3.3V	-	450	600	
Line Regulation	ΔVLNR	VIN=(VOUT+0.5V) to 7.5V, IOUT=1mA	+25°C	-	0.1	0.2	%/V	
Load Regulation	ΔVOUT	IOUT=0.1mA to 500mA, COUT=1uF	+25°C	-	25	50	mV	
		IOUT=0.1mA to 500mA, COUT=1uF, HCR2138-ADJ	+25°C	-	0.5	10	mV	
Output Voltage Noise	en	f=10HZ to 100KHz, CBP=0.01uF, COUT=10uF, IOUT=30mA	+25°C	-	68	-	uVRMS	
Output Voltage Temperature Coefficient	$\frac{\Delta V_{OUT}}{\Delta T_A \times V_{OUT}}$	ILOAD=0.1mA	FULL	-	35	-	ppm/°C	
Power Supply Rejection Ratio	PSRR	CIN=1uF, IOUT=30mA COUT=1uF, VIN=VOUT+1V	f=217Hz	+25°C	-	72	-	dB
			f=1KHz	+25°C	-	70	-	
<b>SHUTDOWN</b>								
EN Input Threshold	VIH	VIN=7.5V	FULL	2.3	-	-	V	
	VIL			-	-	0.8		
EN Input Bias Current	IBH	EN=7.5V	+25°C	-	0.01	1.0	uA	
EN Input Bias Current	IBL	EN=0V	FULL	-	0.01	-		
Shutdown Supply Current	Iq(SHDN)	EN=0V	FULL	-	0.01	1.0	uA	
Start-Up Time <sup>(3)</sup>	tSTR	COUT=1uF, No load	+25°C	-	180	-	us	
RON of Discharge MOSFET		VIN=4V, VEN=0V	+25°C	-	260	-	Ω	
<b>THERMAL PROTECTION</b>								
Thermal Shutdown Temperature	TSHDN			-	150	-	°C	
Thermal Shutdown Hysteresis	ΔTSHDN			-	15	-	°C	

note 1. VIN = VOUT (NOMINAL) + 0.5V or 1.7V, whichever is greater.

2. The dropout voltage is defined as VIN - VOUT, when VOUT is 100mV below the value of VOUT for VIN = VOUT + 0.5V.

3. Time needed for VOUT to reach 90% of final value.

**7.5V, 500mA Low Power, Low Dropout and RF-Linear Regulators**
**Typical Performance Characteristics**

( $V_{IN} = V_{OUT(NOMINAL)} + 0.5V$ ,  $C_{IN} = 1\mu F$ ,  $V_{OUT} = 3.3V$ ,  $C_{OUT} = 1\mu F$ ,  $C_{BP} = 0\mu F$ , at  $T_A = 25^\circ C$ , unless otherwise noted.)

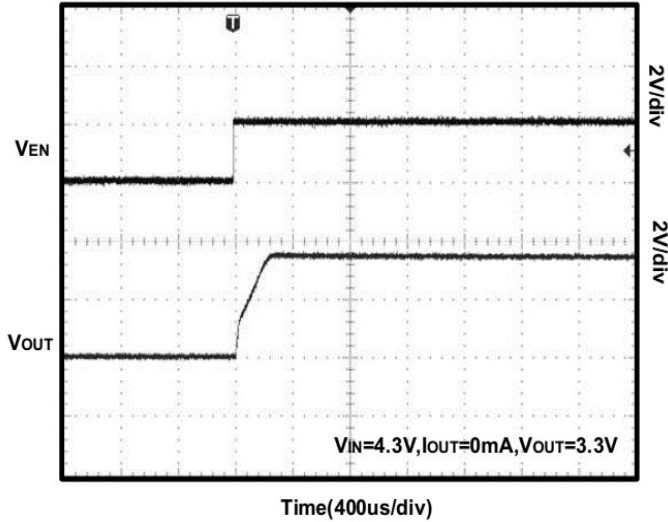
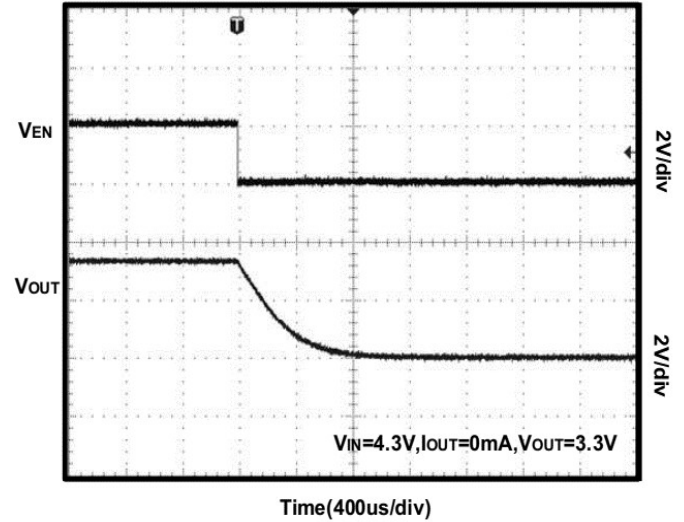
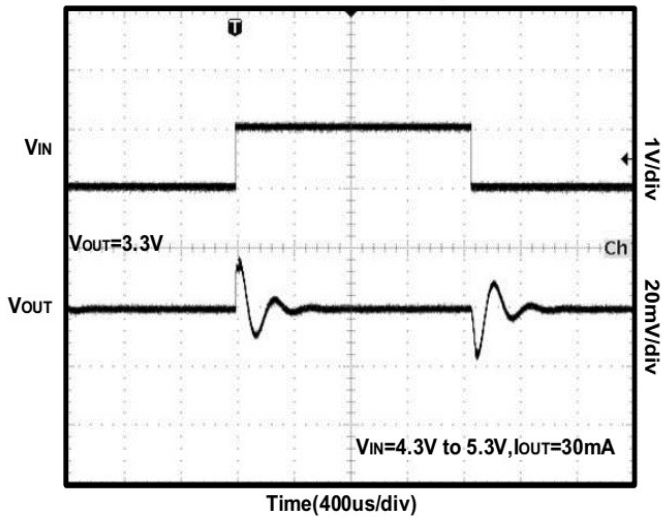
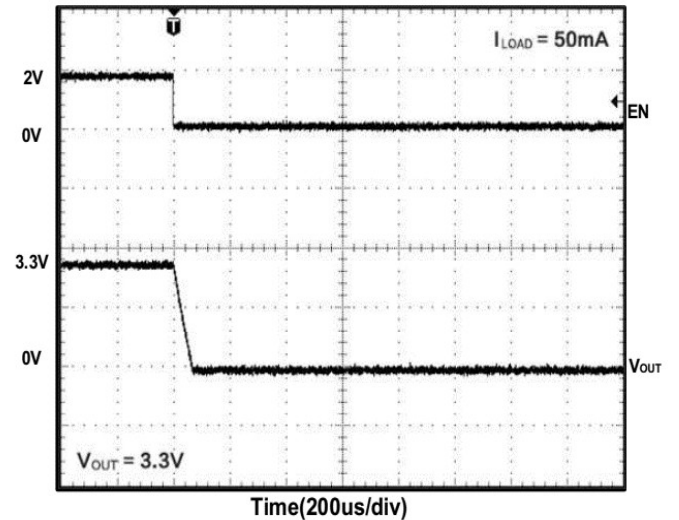
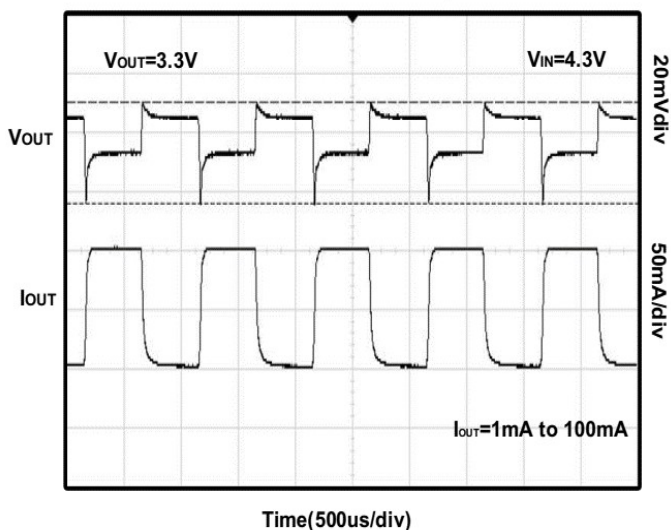
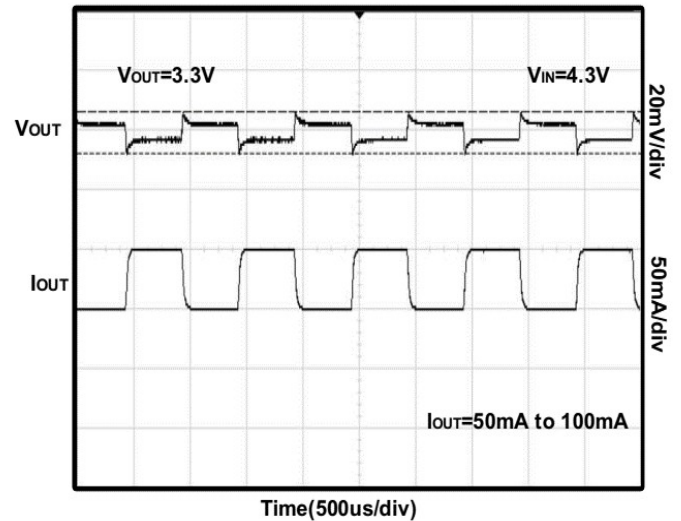
**Turn On Speed With EN Pin**

**Turn Off Speed With EN Pin**

**Line Transient Response**

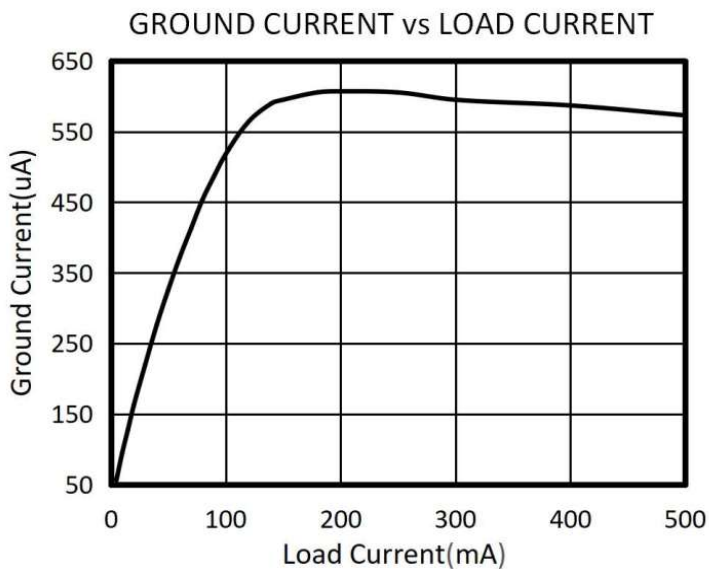
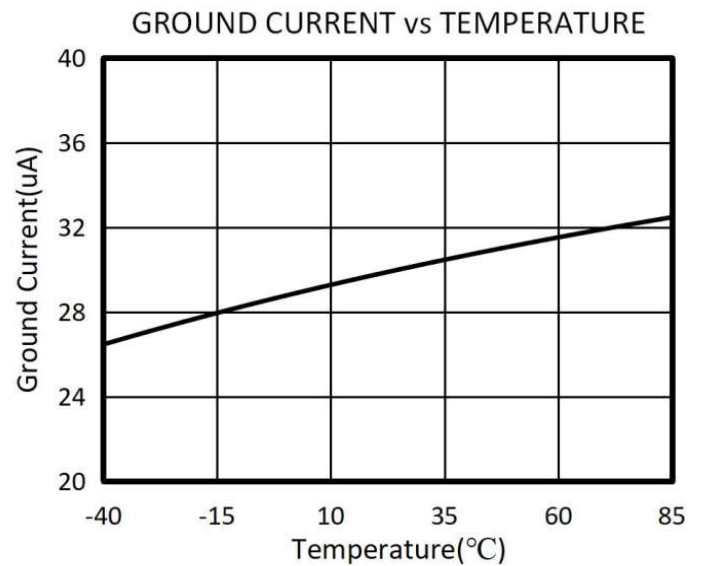
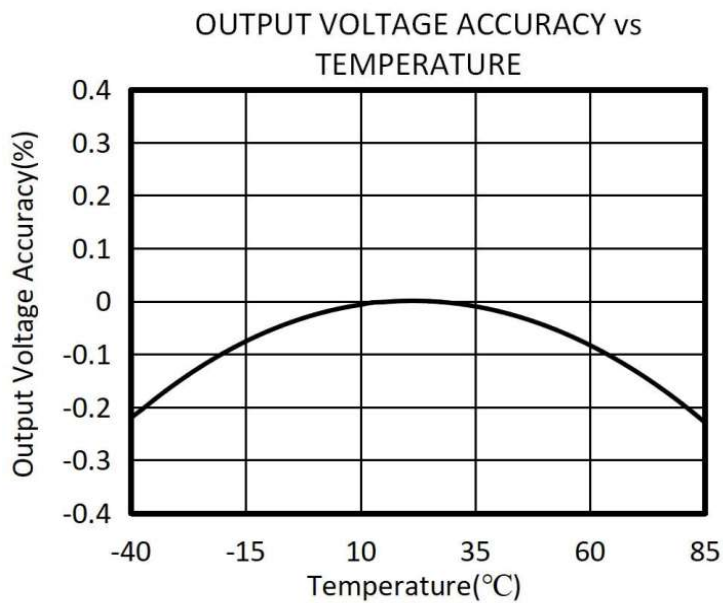
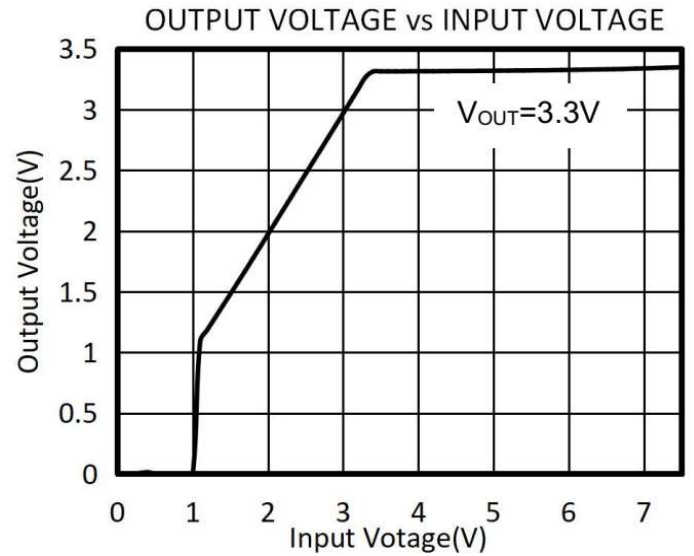
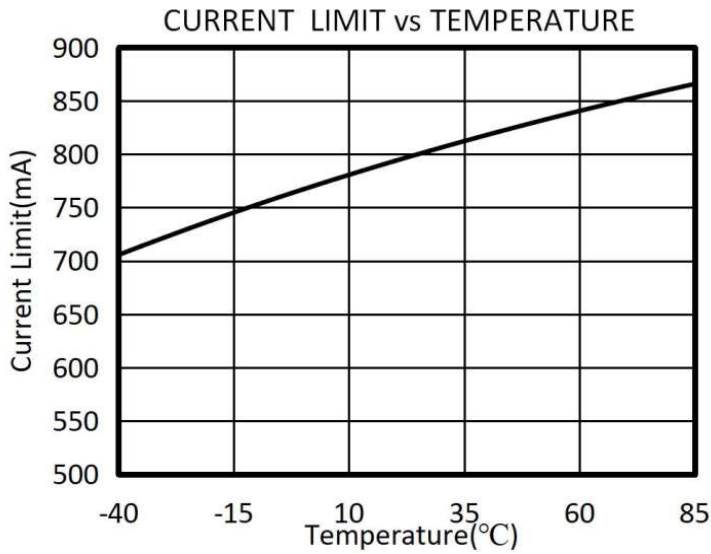
**SHUTDOWN**

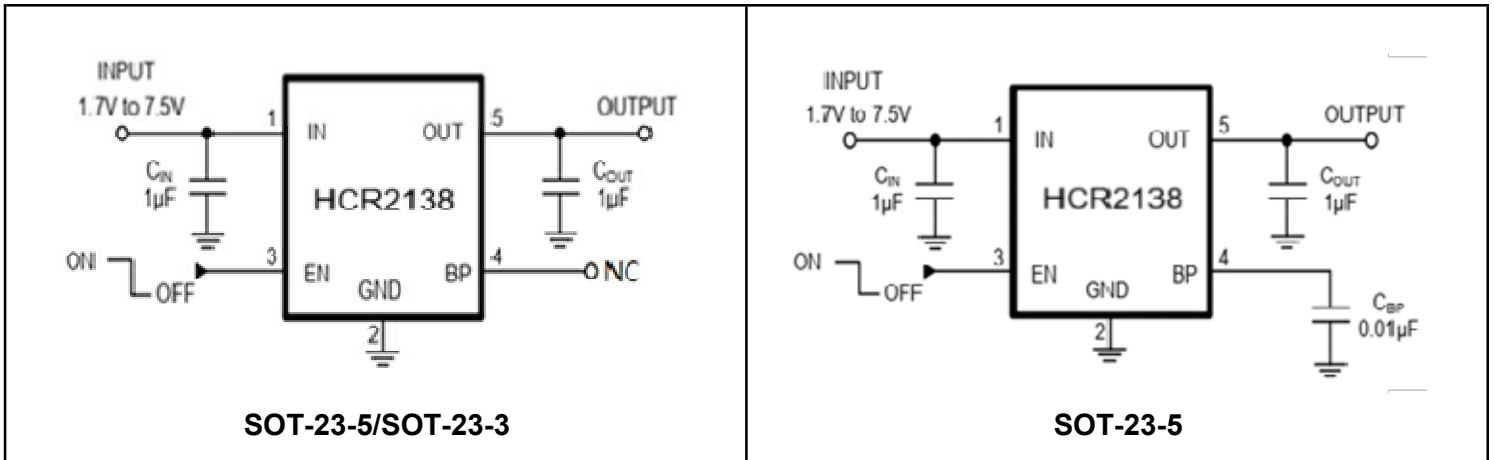
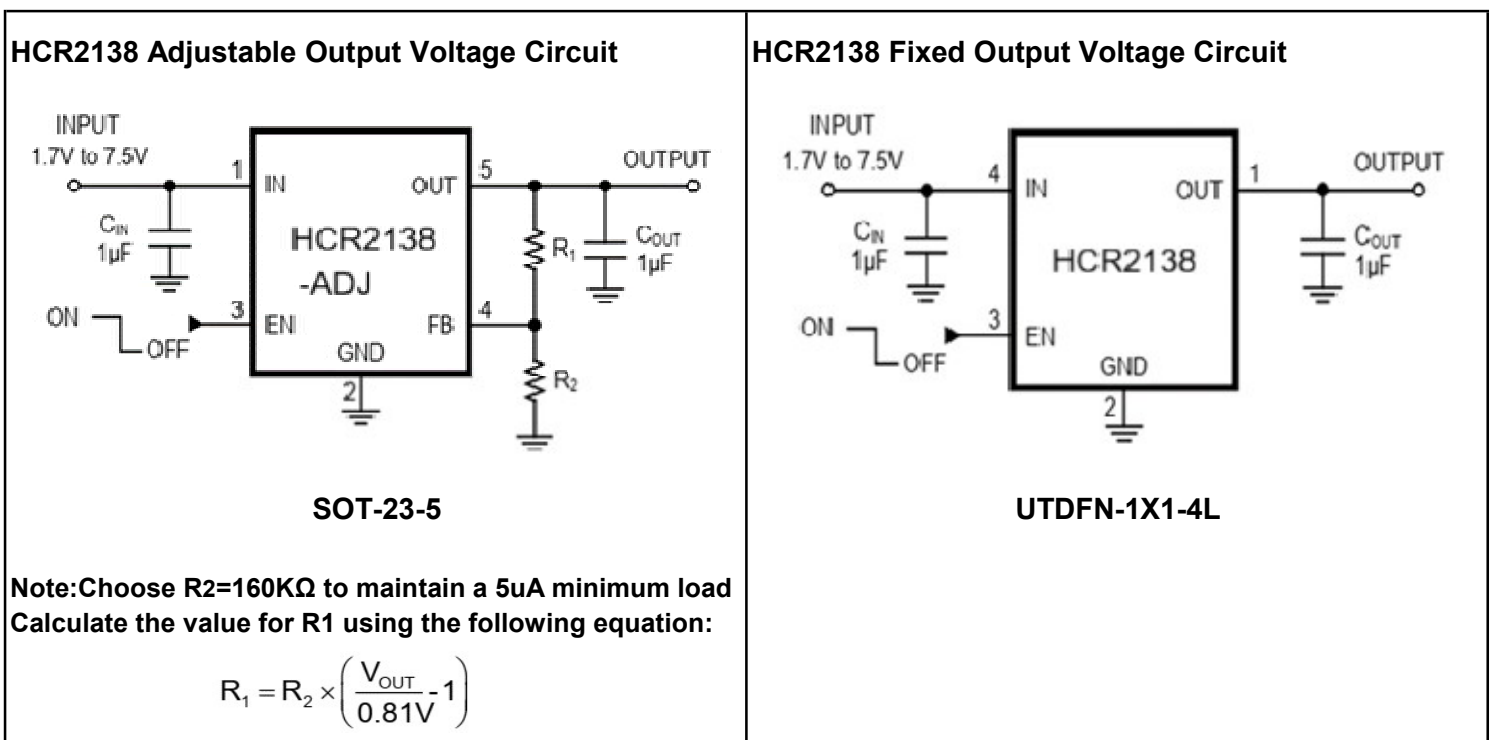
**Load Transient Response**

**Load Transient Response**

**7.5V, 500mA Low Power, Low Dropout and RF-Linear Regulators**
**Typical Performance Characteristics(Con.)**

( $V_{IN}=V_{OUT(NOMINAL)}+0.5V$ ,  $C_{IN}=1\mu F$ ,  $V_{OUT}=3.3V$ ,  $C_{OUT}=1\mu F$ ,  $CBP=0\mu F$ , at  $T_A=25^\circ C$ , unless otherwise noted.)



**Typical Application Circuit**
**HCR2138 Fixed Output Voltage Circuit-1**

**Figure 4. Fixed Output Voltage Circuit of HCR2138**
**Typical Application Circuit Circuit-2**

**Figure 5. Adjustable Output Voltage Circuit**
**Figure 6. Fixed Output Voltage Circuit**

**7.5V, 500mA Low Power, Low Dropout and RF-Linear Regulators**
**APPLICATION NOTE**
**Input Capacitor**

A 1uF ceramic capacitor is recommended to connect between VDD and GND pins to decouple input power supply glitch and noise. The amount of the capacitance may be increased without limit. This input capacitor must be located as close as possible to the device to assure input stability and less noise. For PCB layout, a wide copper trace is required for both VIN and GND.

**Output Capacitor**

An output capacitor is required for the stability of the LDO. The recommended output capacitance is 1uF, ceramic capacitor is recommended, and temperature characteristics are X7R or X5R, Higher capacitance values help to improve load/line transient response. The output capacitance may be increased to keep low undershoot/overshoot. Place output capacitor as close as possible to VOUT and GND pins.

**Dropout Voltage**

The dropout voltage refers to the voltage difference between the VIN and VOUT pins while operating at specific output current. The dropout voltage VDROP also can be expressed as the voltage drop on the pass-FET at specific output current(IRATED) while the pass-FET is fully operating at ohmic region and the pass-FET can be characterized as a resistance RDS(ON). Thus the dropout voltage can be defined as (VDROP=VIN-VOUT=RDS(ON)XIRATED). For normal operation, the suggested LDO operating range is (VIN>VOUT+VDROP) for good transient response and PSRR ability.

Vice versa, while operating at the ohmic region will degrade the performance severely.

**Thermal Application**

For continuous operation, don't exceed the absolute maximum junction temperature. The maximum power dissipation depends on the thermal resistance of the IC package, PCB layout, rate of surrounding airflow, and difference between junction and ambient temperature. The maximum power dissipation can be calculated as below: TA=25°C, PCB, The max

$$P_{D(Max)} = (125^{\circ}\text{C} - 25^{\circ}\text{C}) / (250^{\circ}\text{C/W}) = 0.5\text{W}$$

for SOT23-5 packages.

power dissipation(PD) is equal to the product of the output current and the voltage drop across the output pass element, as shown in the equation below:

$$P_D = (V_{IN} - V_{OUT}) \times I_{OUT}$$

**Layout Consideration**

By placing input and output capacitors on the same side of the PCB as the LDO, and placing them as close as is practical to the package can achieve the best performance. The ground connections for input and output capacitors must be back to the HCR2138 ground pin using as wide and as short of a copper trace as is practical. Connections using long trace lengths, narrow trace widths, and/or connections through via must be avoided. These add parasitic inductances and resistance that results in worse performance especially during transient conditions.

**USB interface application**

Figure 7. USB interface application of HCR2138

**Mechanical Dimensions**
**PKG:UTDFN-1X1-4L (DN14L)**
**Unit: mm (inch)**

**TOP VIEW**

**BOTTOM VIEW**

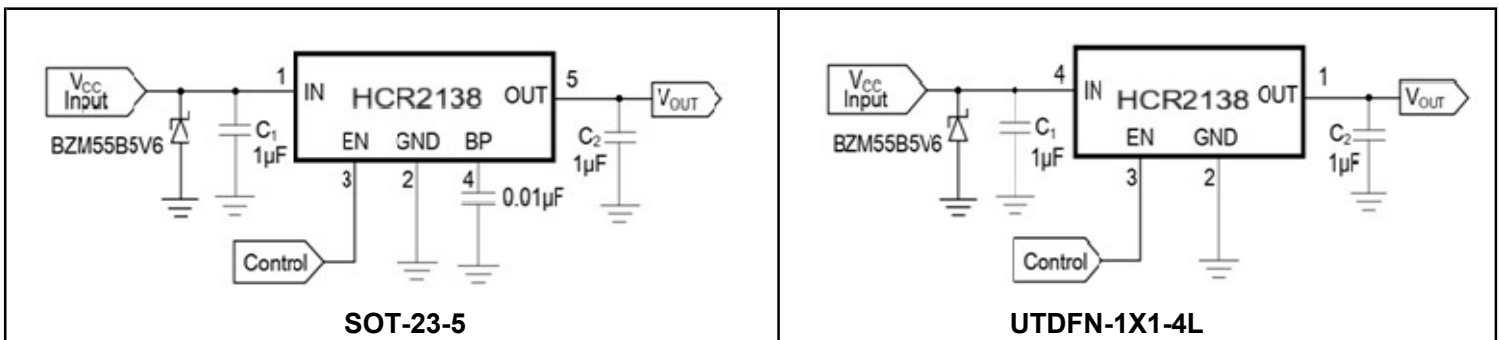
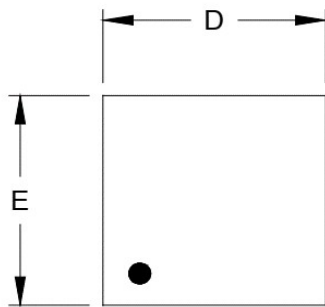
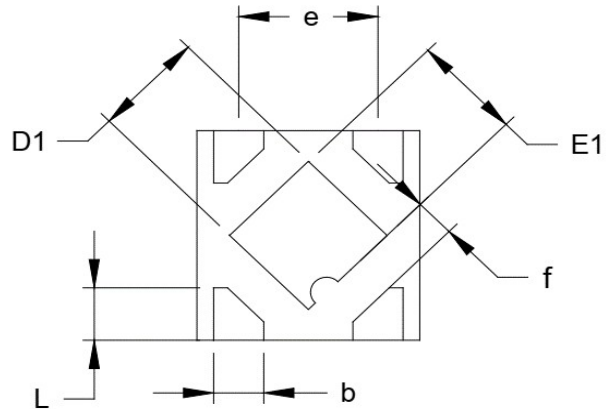
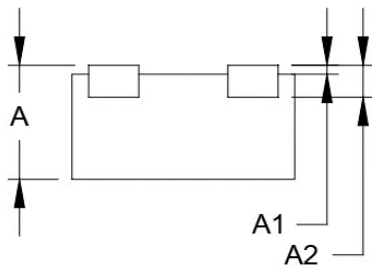
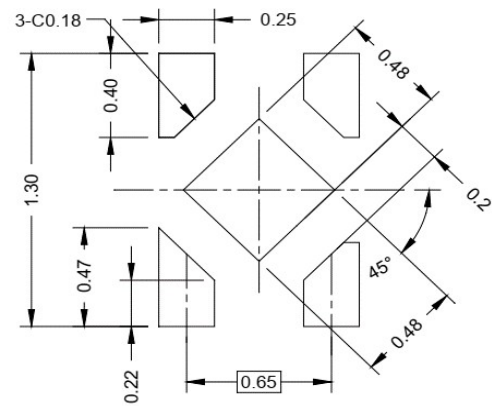
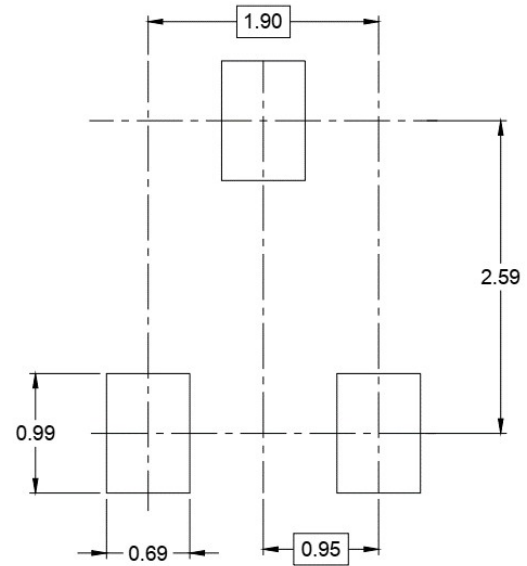
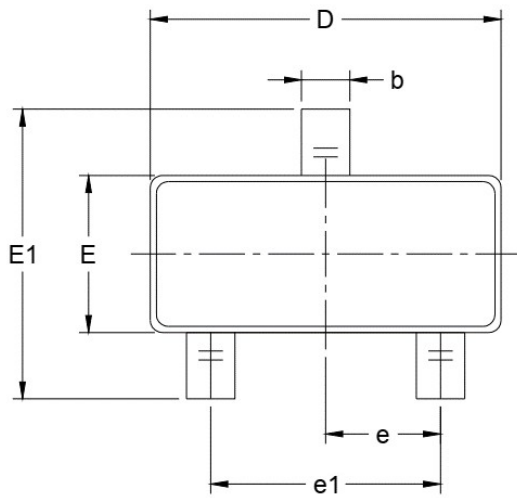
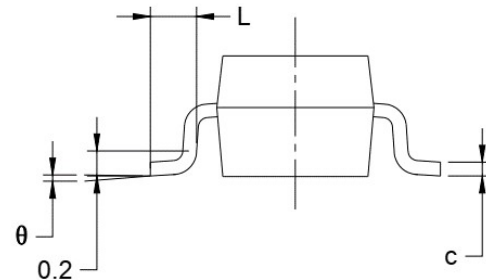
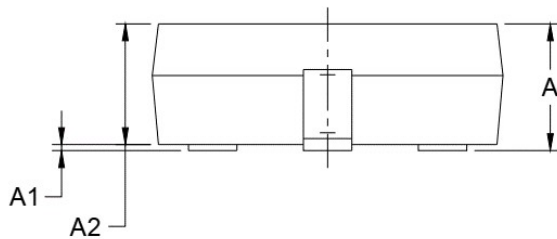
**SIDE VIEW**

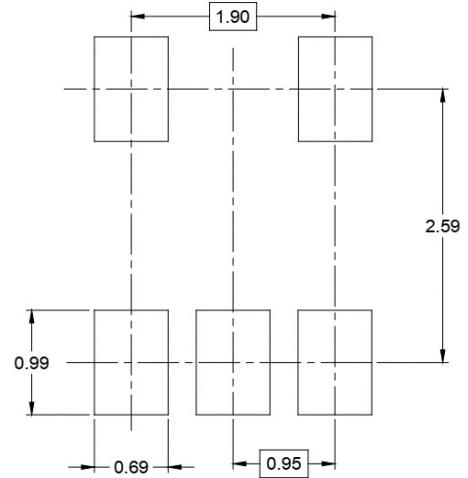
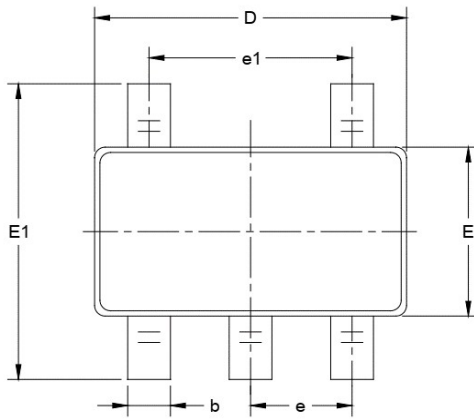
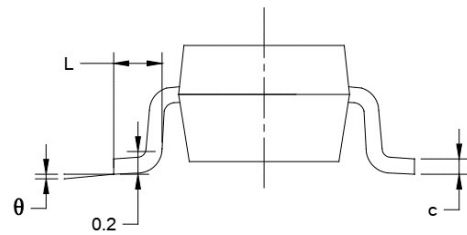
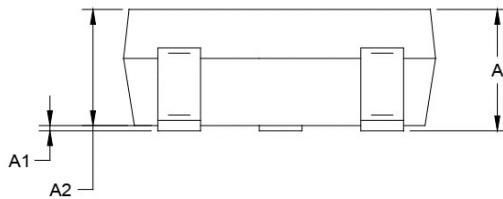
**RECOMMENDED LAND PATTERN (Unit: mm)**

Symbol	Dimensions In Millimeters		
	MIN	MOD	MAX
A	0.500	0.550	0.600
A1	0.000		0.050
A2	0.152 REF		
D	0.950	1.000	1.050
D1	0.450	0.500	0.550
E	0.950	1.000	1.050
E1	0.450	0.500	0.550
b	0.175	0.225	0.275
e	0.625 BSC		
f	0.195 REF		
L	0.200	0.250	0.300

**7.5V, 500mA Low Power, Low Dropout and RF-Linear Regulators**
**Mechanical Dimensions(Con.)**
**PKG:SOT-23-3 (M3)**
**Unit: mm (inch )**

**RECOMMENDED LAND PATTERN (Unit: mm)**

Symbol	Dimensions In Millimeters		Dimensions In Inches	
	MIN	MAX	MIN	MAX
A	1.050	1.250	0.041	0.049
A1	0.000	0.100	0.000	0.004
A2	1.050	1.150	0.041	0.045
b	0.300	0.500	0.012	0.020
c	0.100	0.200	0.004	0.008
D	2.820	3.020	0.111	0.119
E	1.500	1.700	0.059	0.067
E1	2.650	2.950	0.104	0.116
e	0.950 BSC		0.037 BSC	
e1	1.900 BSC		0.075 BSC	
L	0.300	0.600	0.012	0.024
θ	0°	8°	0°	8°

**Mechanical Dimensions**
**PKG:SOT-23-5 (M5)**
**Unit: mm (inch )**

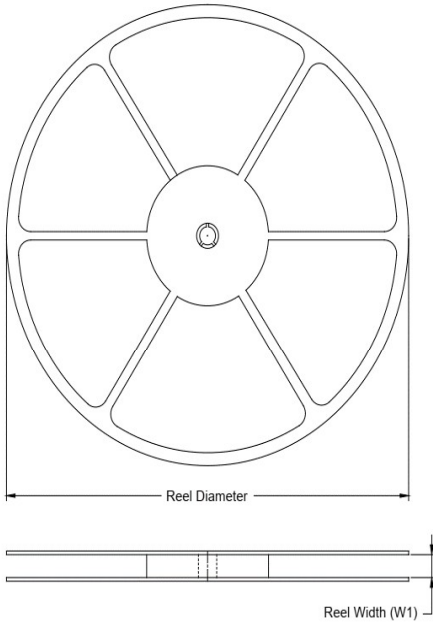
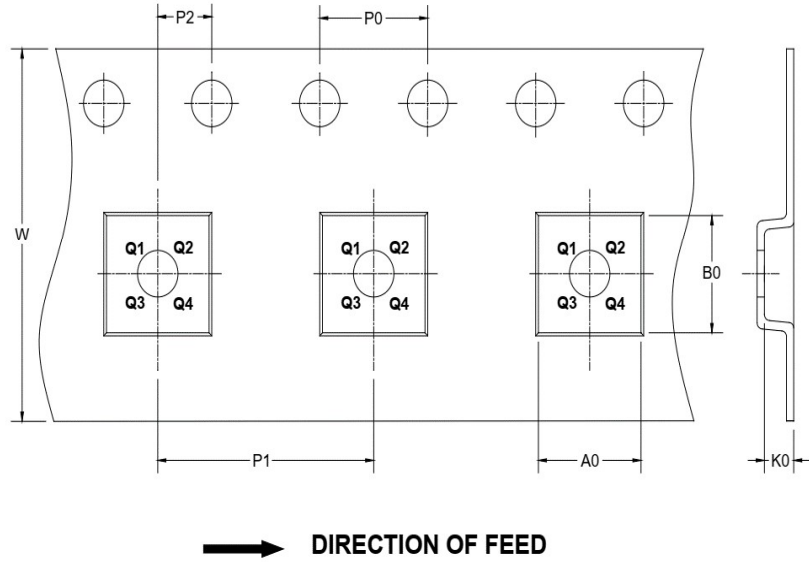
**RECOMMENDED LAND PATTERN (Unit: mm)**

Symbol	Dimensions In Millimeters		Dimensions In Inches	
	MIN	MAX	MIN	MAX
A	1.050	1.250	0.041	0.049
A1	0.000	0.100	0.000	0.004
A2	1.050	1.150	0.041	0.045
b	0.300	0.500	0.012	0.020
c	0.100	0.200	0.004	0.008
D	2.820	3.020	0.111	0.119
E	1.500	1.700	0.059	0.067
E1	2.650	2.950	0.104	0.116
e	0.950 BSC		0.037 BSC	
e1	1.900 BSC		0.075 BSC	
L	0.300	0.600	0.012	0.024
θ	0°	8°	0°	8°

**TAPE AND REEL INFORMATION**
**REEL DIMENSIONS**

**TAPE DIMENSIONS**

NOTE: The picture is only for reference. Please make the object as the standard.

**KEY PARAMETER LIST OF TAPE AND REEL**

Package Type	Reel Diameter	Reel Width W1 (mm)	A0 (mm)	B0 (mm)	K0 (mm)	P0 (mm)	P1 (mm)	P2 (mm)	W (mm)	Pin1 Quadrant
SOT-23-5	7"	9.5	3.20	3.20	1.40	4.0	4.0	2.0	8.0	Q3
UTDFN-1×1-4	7"	9.0	1.16	1.16	0.63	4.0	2.0	2.0	8.0	Q1
SOT-23-3	7"	9.0	3.20	3.3	1.3	4.0	4.0	2.0	8.0	Q3

7.5V, 500mA Low Power, Low Dropout and RF-Linear Regulators

**CARTON BOX DIMENSIONS**

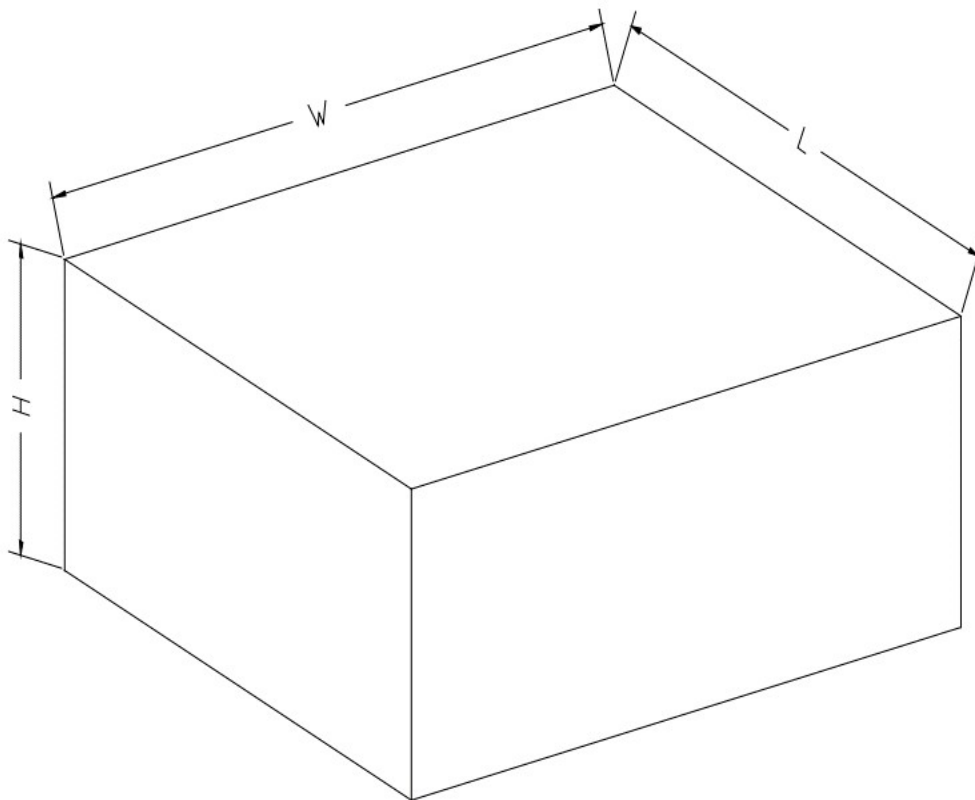

NOTE: The picture is only for reference. Please make the object as the standard.

**KEY PARAMETER LIST OF CARTON BOX**

Reel Type	Length (mm)	Width (mm)	Height (mm)	Pizza/Carton
7" (Option)	368	227	224	8
7"	442	410	224	18