

Low distortion, Low-noise, High Voltage Dual Operational Amplifiers**Features**

- * Low Distortion: 0.0005%
- * Large Signal Voltage Gain: 110dB Typical
- * Operating Voltage: up to 36V (dual \pm 18V)
- * Low Noise Voltage: 0.46 μ V \sqrt Hz
- * High Slew Rate: 6V/us Typical
- * Wide Gain Bandwidth: 15MHz at 10KHz
- * Operating Temperature range: -40°C to +125°C

Applications

- * Audio AC-3 Decoder System
- * Audio Amplifier
- * Low Noise Amplifier Front End
- * DAC Output Amplifier
- * Precision Instrumentation

General Description

The HCR4580 is a high performance, low noise dual operational amplifier. It is specifically designed for audio systems to improve tone control; it can be used in pre-amplifier, industrial measurement tools and applications where gain and phase matched channels are mandatory.

The HCR4580 feature internal frequency compensation, low noise, low distortion, high gain and high bandwidth. The HCR4580 can operate under dual power supply voltage up to \pm 18V or single power supply up to 36V.

The HCR4580 is available in Green SOIC-8(SOP8), TSSOP-8, MSOP8 and DIP-8 package. It is specified over the extended -40°C to +125°C temperature range.

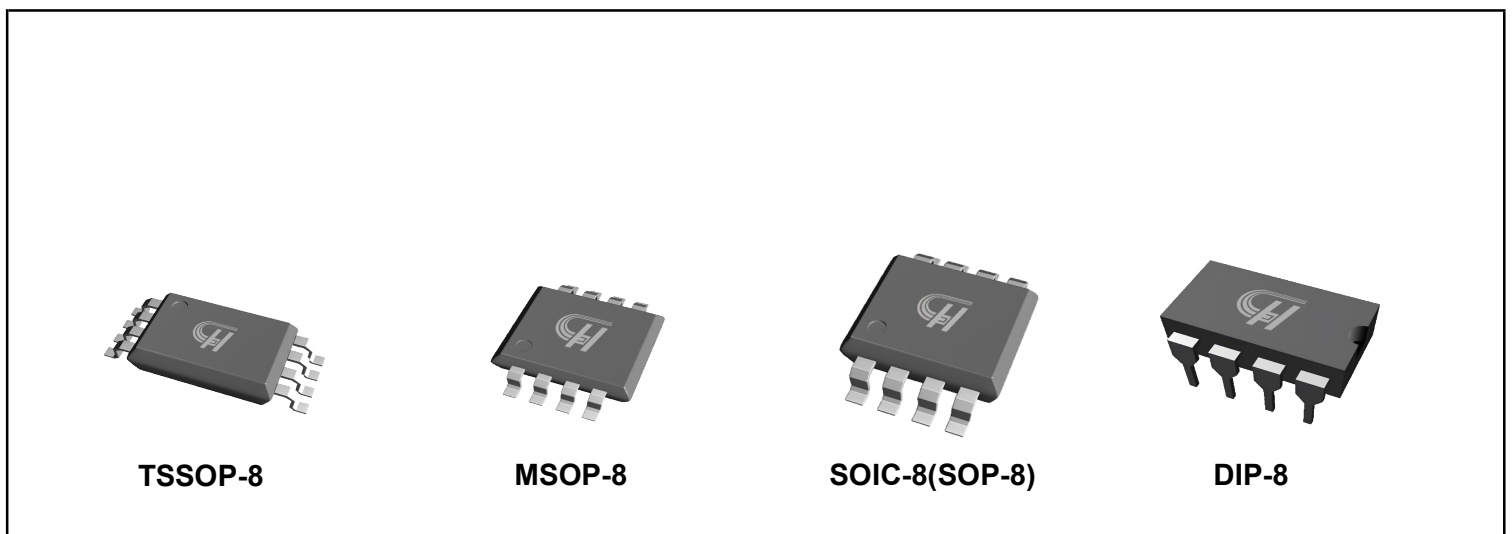

Figure 1. Package Type of HCR4580

Low distortion, Low-noise, High Voltage Dual Operational Amplifiers
Pin Configuration

Figure 2. Pin Configuration of HCR4580 (Top View)

Pin Function Table

Pin	Name	Function
3, 5	+IN A, +IN B	Non-inverting Inputs
2, 6	-IN A, -IN B	Inverting Inputs
8	+Vs	Positive Power Supply
4	-Vs	Negative Power Supply
1, 7	OUTA, OUTB	Outputs

Ordering Information

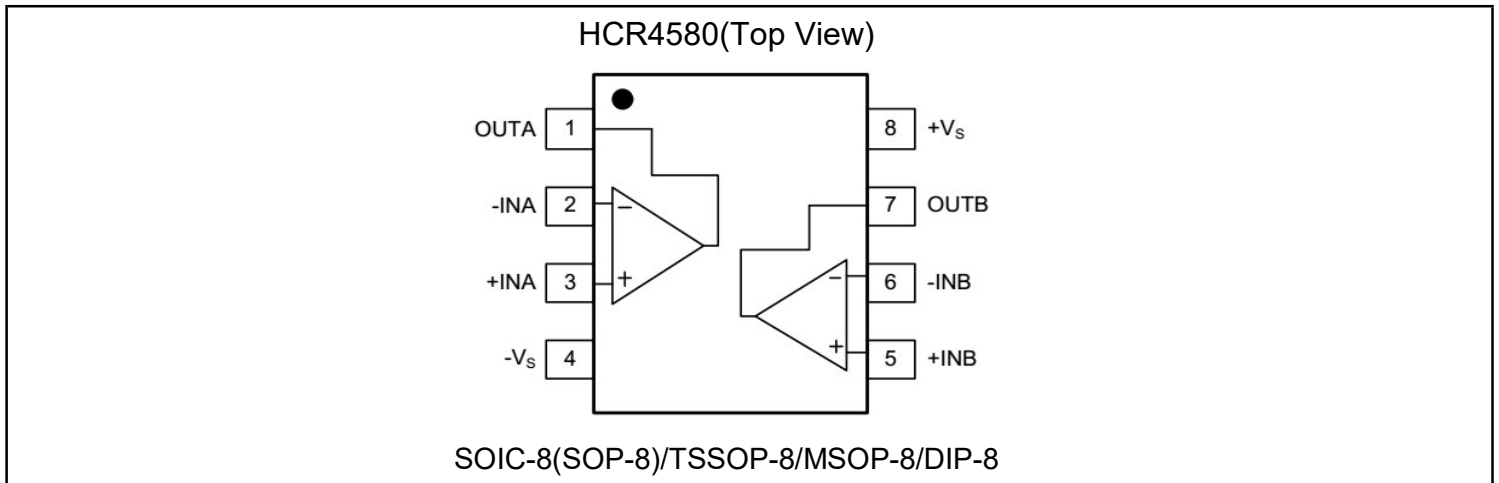
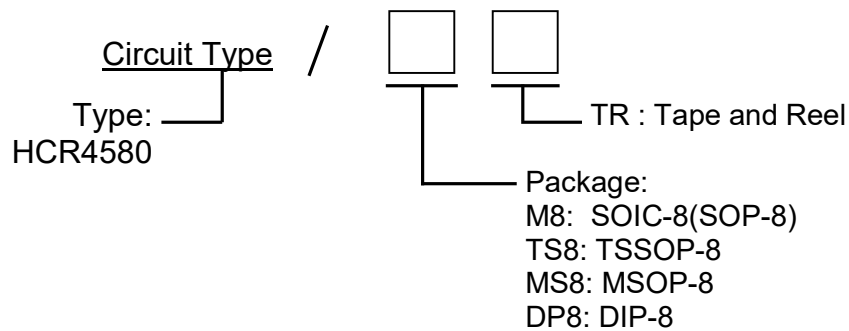
Ordering Code

Part Number	Marking ID ^{note1}	Temperature Range	Package	Package Type
HCR4580/M8TR	HCR4580MXX	-40'C to +125'C	SOIC-8 (SOP-8)	4000pcs/TR
HCR4580/TS8TR	HCR4580TXX	-40'C to +125'C	TSSOP-8	5000pcs/TR
HCR4580/MS8TR	HCR4580SXX	-40'C to +125'C	MSOP-8	4000pcs/TR
HCR4580/DP8TR	HCR4580DXX	-40'C to +125'C	DIP-8	1K/Tuble

Note 1. the "XX" is date code as refer to message

Low distortion, Low-noise, High Voltage Dual Operational Amplifiers

Functional Block Diagram

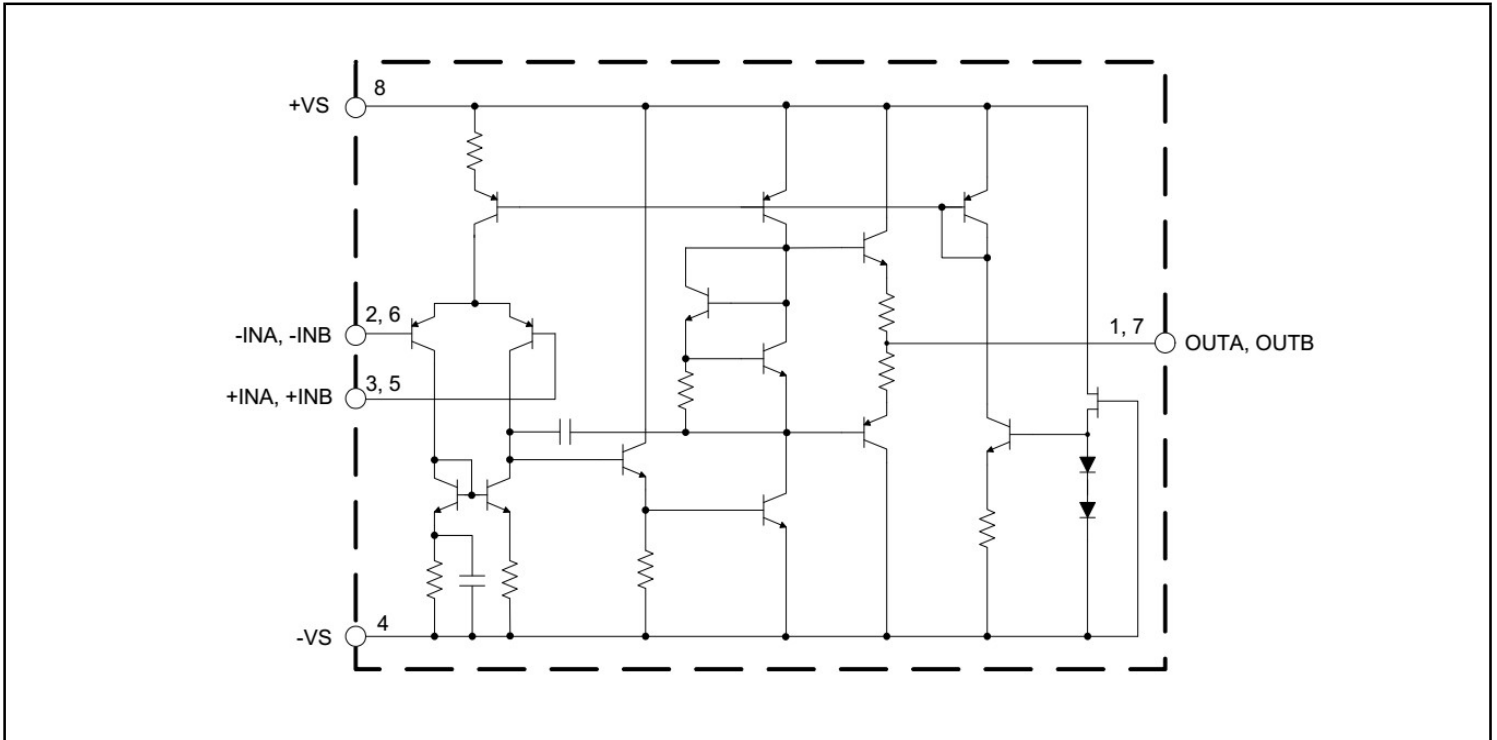

Figure 3. Pin Configuration of HCR4580 (Top View)

Typical Applications

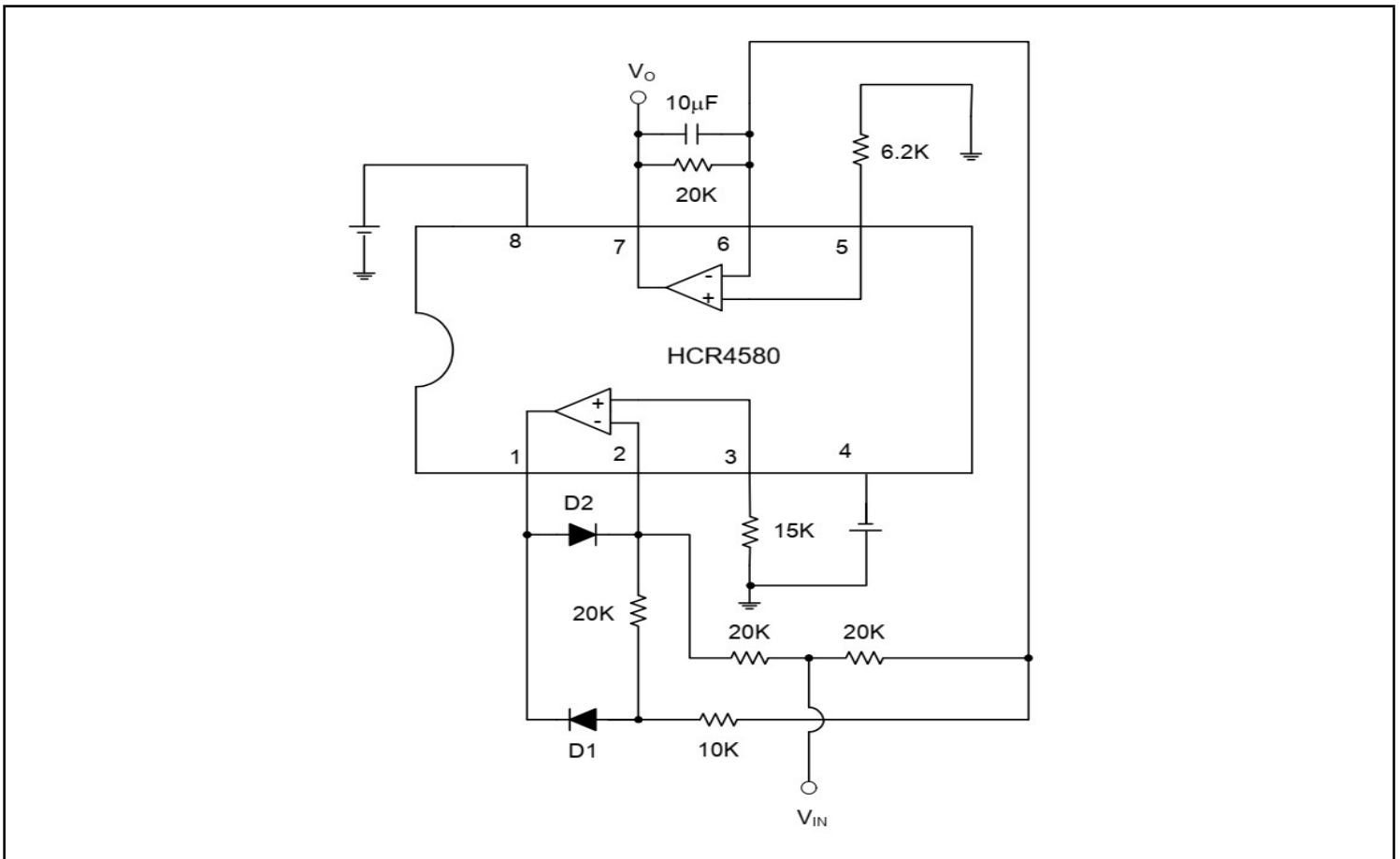

Figure 4. Application of HCR4580 in an AC/DC Converter

Low distortion, Low-noise, High Voltage Dual Operational Amplifiers
Absolute Maximum Ratings ^{Note 2}

Parameter		Symbol	Value	Unit
Supply Voltage, +Vs to -Vs		V+	+20	V
		V-	-20	
Input Voltage, VIN		VIN	±15	V
Differential Input Voltage		VDF	±30	V
Power Dissipation @TA=+25°C	TSSOP-8	PD	400	mW
	MSOP-8		420	mW
	SOIC-8 /SOP-8		500	mW
	DIP-8		800	mW
Storage Temperature Range		TSTG	-65 to +150	°C
Operating Temperature Range ^{note 2}		TOPR	-40 to +125	°C
Junction Temperature		TJ	+150	°C
Lead Temperature (Soldering, 10s)		TLEAD	260	°C

Note 2: Stresses above those listed under "Maximum Ratings" may cause permanent damage to the device.

This is a stress rating only and functional operation of the device at those or any other conditions above those indicated in the operational listings of this specification is not implied. Exposure to maximum rating conditions for extended periods may affect device reliability.

Recommended Operating Conditions

Parameter	Symbol	Min	Max	Unit
Supply Voltage V+ to V-	V+, V-	±2.0	±18.0	V
Operating Temperature Range	TA	-40	+125	°C

Low distortion, Low-noise, High Voltage Dual Operational Amplifiers
Electrical Characteristics

(Operating Conditions: +Vs=+15V, -Vs=-15V, Ta=25 `C, Unless Otherwise Specified.)

Parameter	Symbol	Conditions	Min	Type	Max	Unit
Supply Current	I _o	no load	-	4.0	7.0	mA
Input Offset Voltage	V _{IO}	R _s ≤10KΩ	-	0.5	3.0	mV
Input Offset Current	I _{IO}	V _{CM} =0V	-	5.0	100	nA
Input Bias Current	I _B	V _{CM} =0V	-	150	500	nA
Maximum Output Voltage Swing	V _{OM}	R _L ≥2KΩ	±12	±13.5	-	V
Input Common Mode Voltage Range	V _{ICM}		±12	±13.5	-	V
Common Mode Rejection Ratio	CMRR	V _{CM} =0V to V _{CC} -1.5V, R _s ≤10KΩ	80	110	-	dB
Large Signal Voltage Gain	A _v	R _L =2KΩ, V _o =±10V	90	110	-	dB
Power Supply Rejection Ratio	PSRR	R _s =10KΩ	80	110	-	dB
Output Sink Current	I _{O1}	V ₋ =1V, V ₊ =0V, V _o =2V	-	80	-	mA
Output Source Current	I _{O2}	V ₊ =1V, V ₋ =0V, V _o =2V	-	45	-	mA
Slew Rate	SR	R _L ≥2KΩ	-	6.0	-	V/μS
Gain Bandwidth Product	GB	R _L =2KΩ, f=±10KHz	-	15	-	MHz
Unity Gain Bandwidth	f _r	A _v =1	-	5.5	-	MHz
Total Harmonic Distortion	THD	A _v =20dB, V _o =5V, R _L =2KΩ, f=1KHz	-	0.0005	-	%
Equivalent Input Noise Voltage	e _n	f=1KHz R _s =50Ω, 30KHz LPF	-	0.46	0.7	μV √ Hz
Thermal Resistance (Junction to Case)	θ _{Jc}	TSSOP-8	-	86	-	'C/W
		MSOP-8	-	85	-	
		SOIC-8	-	63	-	
		DIP-8	-	43	-	

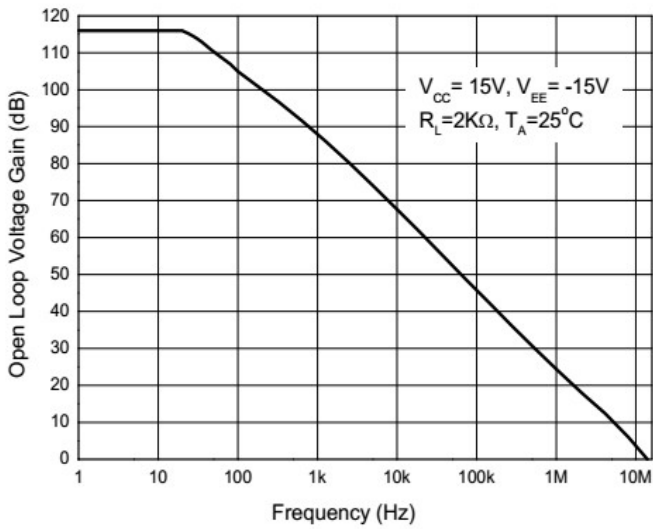
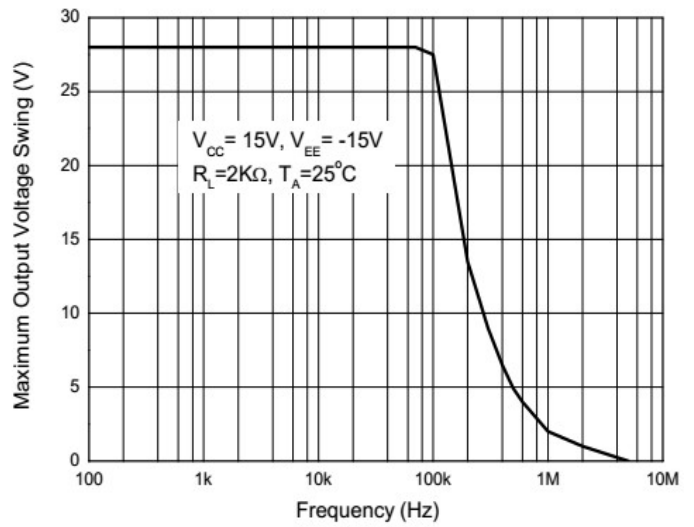
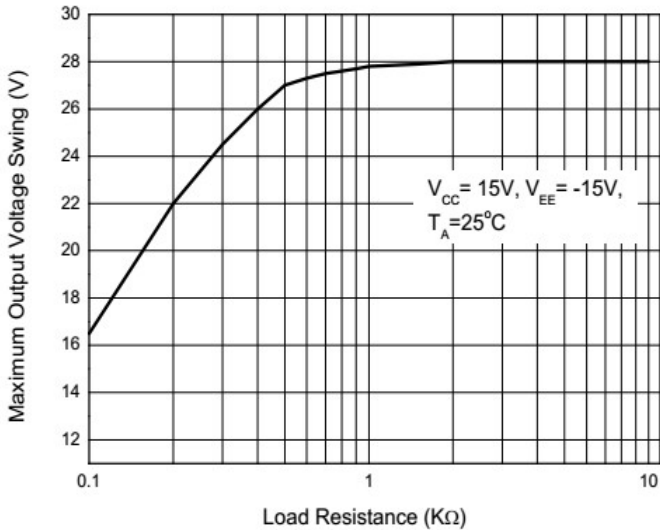
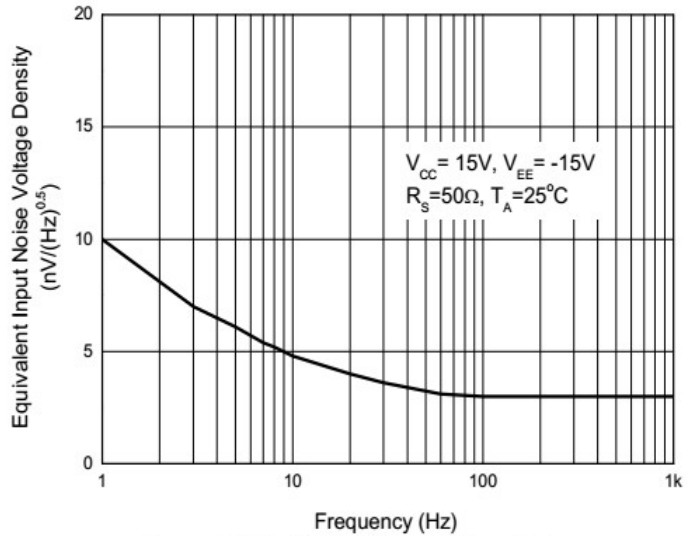
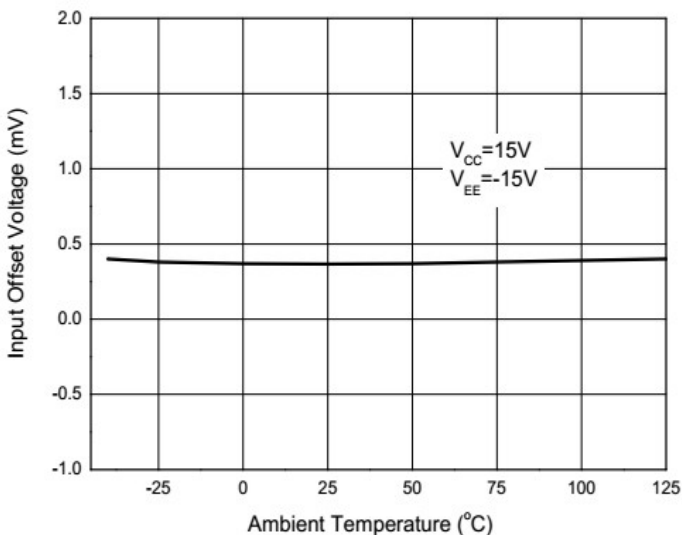
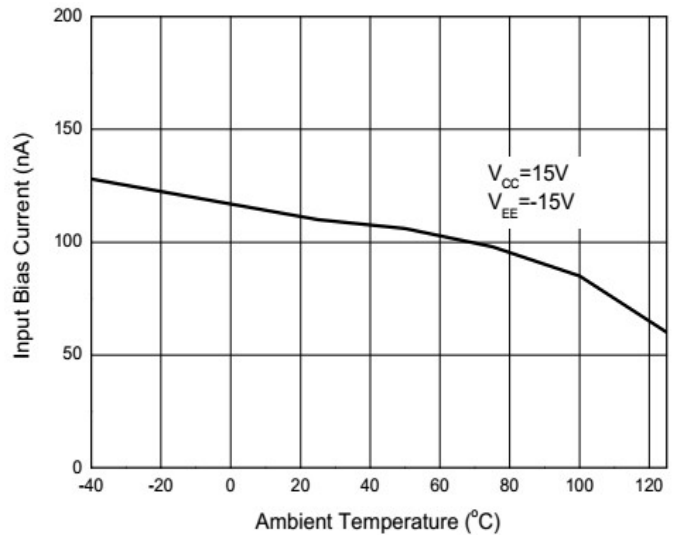
Low distortion, Low-noise, High Voltage Dual Operational Amplifiers
Typical Performance Characteristics

Figure 5. Open Loop Voltage Gain vs. Frequency

Figure 6. Maximum Output Voltage Swing vs. Frequency

Figure 7. Maximum Output Voltage Swing vs. Load Resistance

Figure 8. Equivalent Input Noise Voltage Density vs. Frequency

Figure 9. Input Offset Voltage vs. Temperature

Figure 10. Input Bias Current vs. Temperature

Low distortion, Low-noise, High Voltage Dual Operational Amplifiers

Typical Applications Circuit

- RIAA Preamp Circuit

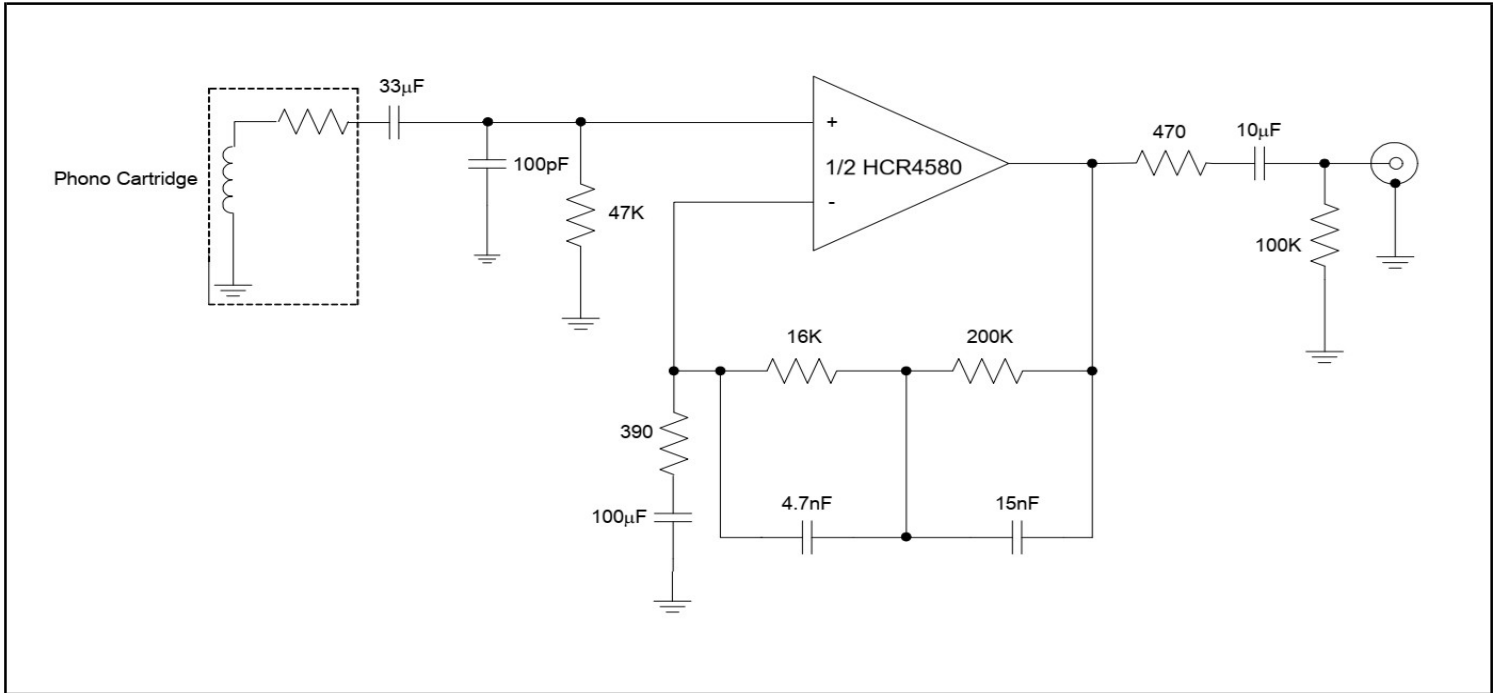

Figure 11. Application of HCR4580 in a RIAA Preamp

- Tone Control Circuit

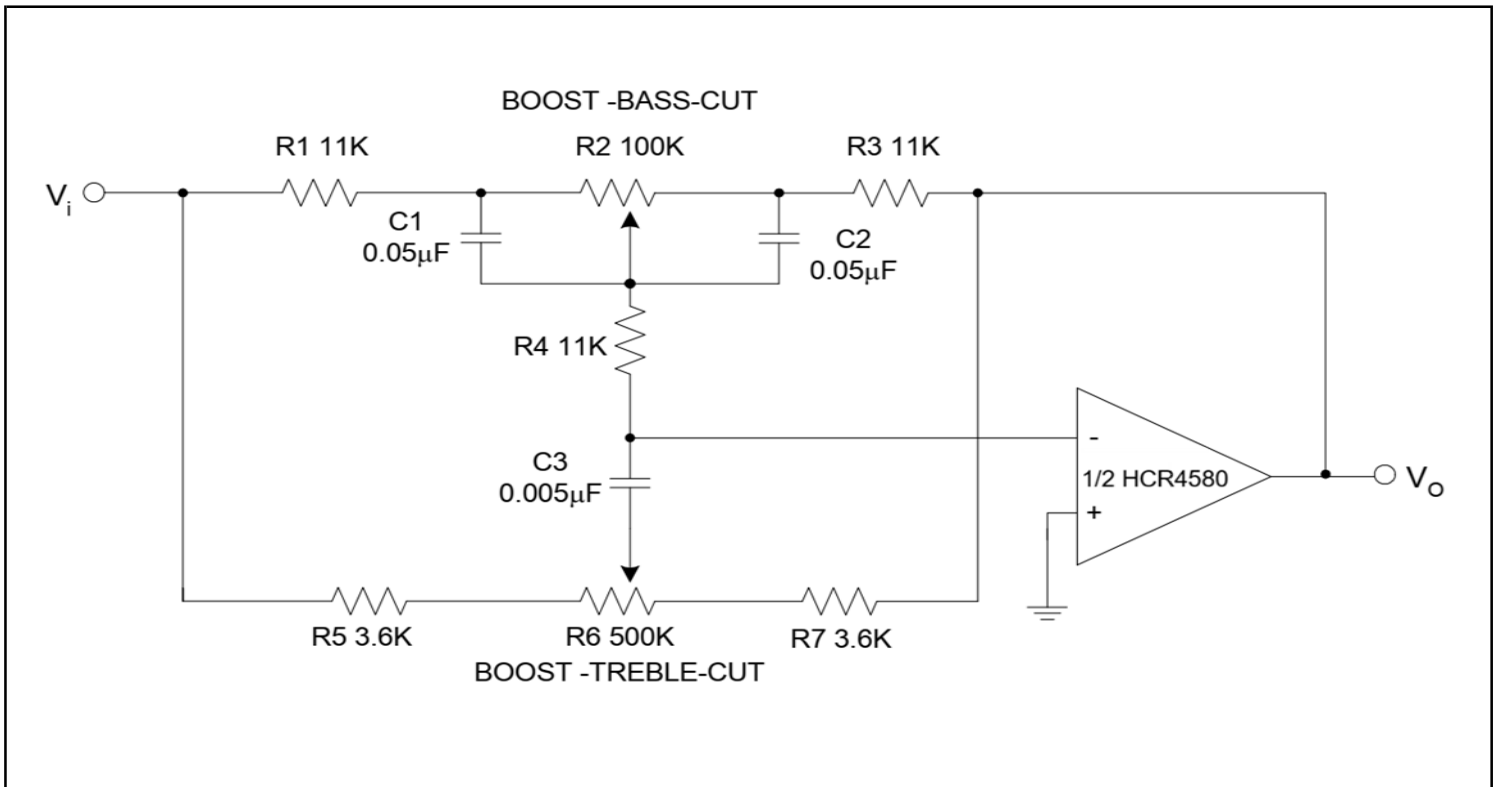
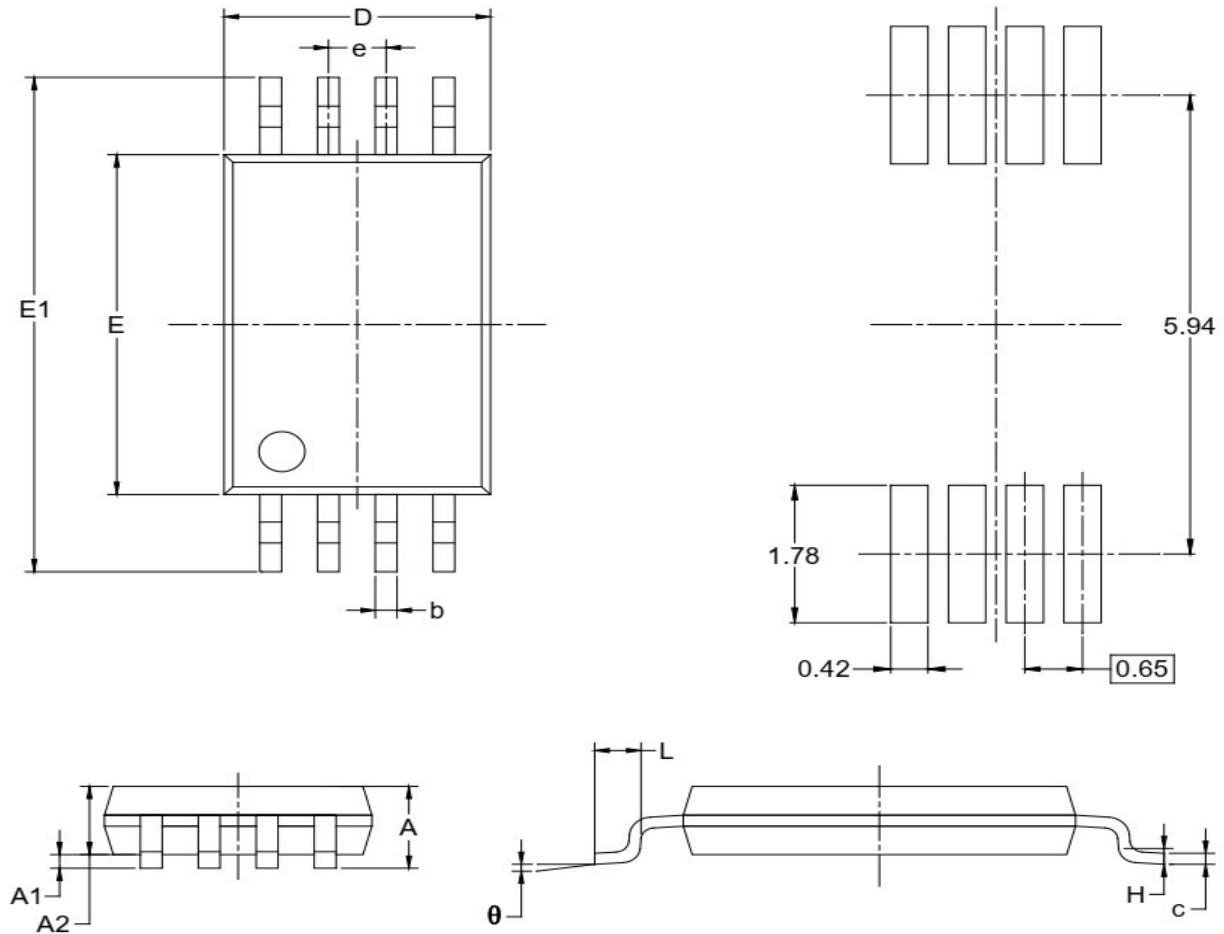

Figure 12. Application of HCR4580 in Tone Control

Low distortion, Low-noise, High Voltage Dual Operational Amplifiers
Mechanical Dimensions

PKG: TSSOP-8(TS8)

Unit: mm (inch)



Symbol	Dimensions In Millimeters		Dimensions In Inches	
	MIN	MAX	MIN	MAX
A		1.100		0.043
A1	0.050	0.150	0.002	0.006
A2	0.800	1.000	0.031	0.039
b	0.190	0.300	0.007	0.012
c	0.090	0.200	0.004	0.008
D	2.900	3.100	0.114	0.122
E	4.300	4.500	0.169	0.177
E1	6.250	6.550	0.246	0.258
e	0.650 BSC		0.026 BSC	
L	0.500	0.700	0.02	0.028
H	0.25 TYP		0.01 TYP	
theta	1°	7°	1°	7°

NOTES:

1. Body dimensions do not include mode flash or protrusion.
2. This drawing is subject to change without notice.

Low distortion, Low-noise, High Voltage Dual Operational Amplifiers
Mechanical Dimensions(con.)

PKG : MSOP-8(MS8)

Unit: mm (inch)

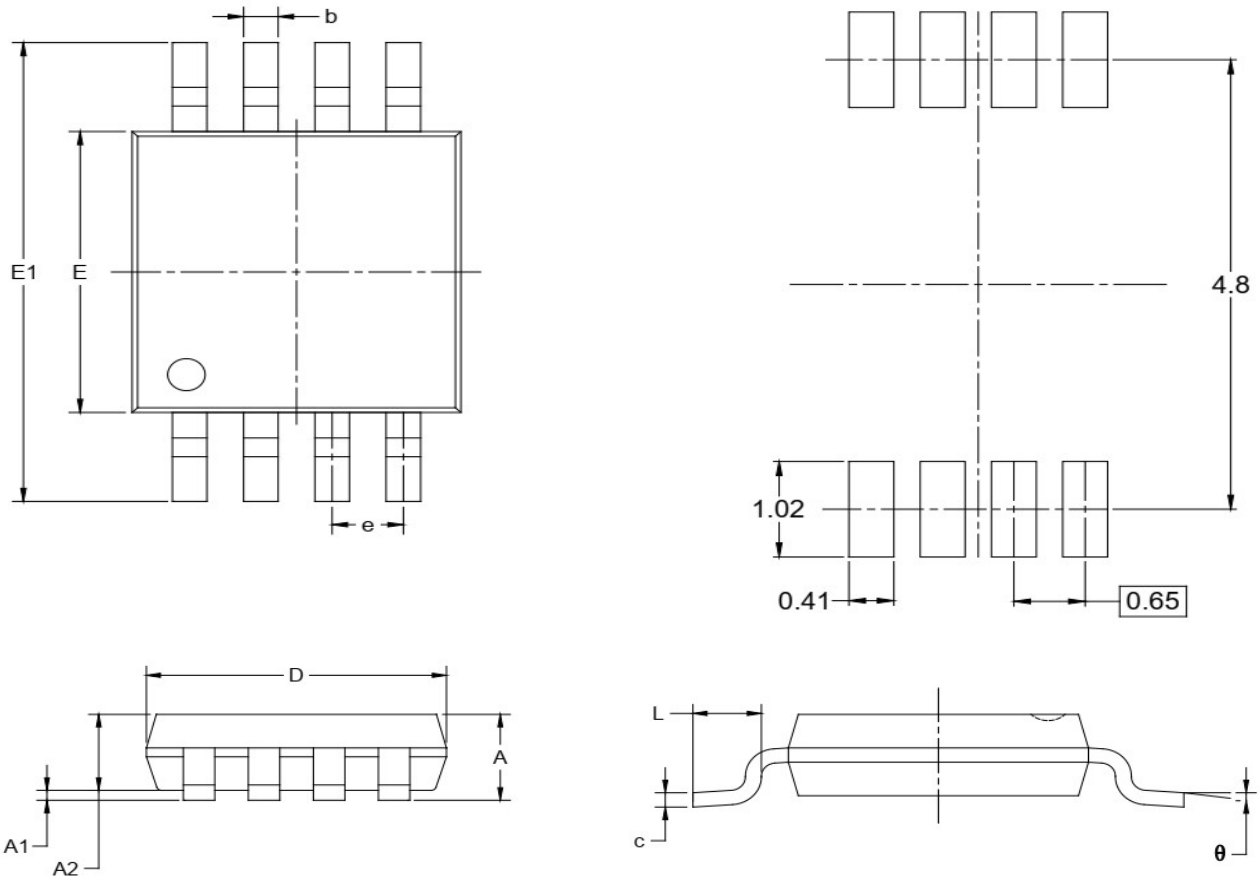

Symbol	Dimensions In Millimeters		Dimensions In Inches	
	MIN	MAX	MIN	MAX
A	0.820	1.100	0.032	0.043
A1	0.020	0.150	0.001	0.006
A2	0.750	0.950	0.030	0.037
b	0.250	0.380	0.010	0.015
c	0.090	0.230	0.004	0.009
D	2.900	3.100	0.114	0.122
E	2.900	3.100	0.114	0.122
E1	4.750	5.050	0.187	0.199
e	0.650 BSC		0.026 BSC	
L	0.400	0.800	0.016	0.031
θ	0°	6°	0°	6°

NOTES:

1. Body dimensions do not include mode flash or protrusion.
2. This drawing is subject to change without notice.

Low distortion, Low-noise, High Voltage Dual Operational Amplifiers
Mechanical Dimensions(con.)

PKG : SOIC-8/SOP-8 (M8)

Unit: mm (inch)

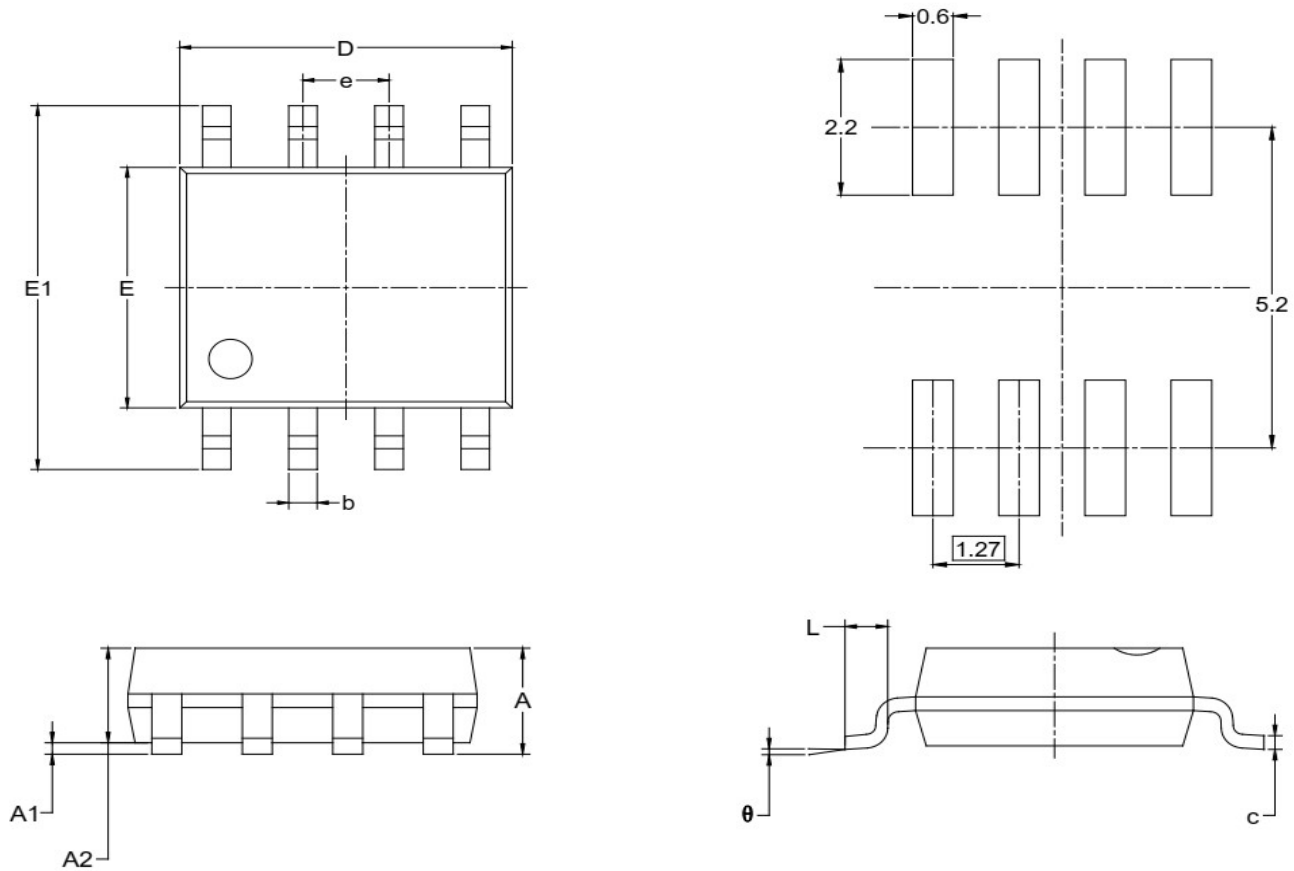

Symbol	Dimensions In Millimeters		Dimensions In Inches	
	MIN	MAX	MIN	MAX
A	1.350	1.750	0.053	0.069
A1	0.100	0.250	0.004	0.010
A2	1.350	1.550	0.053	0.061
b	0.330	0.510	0.013	0.020
c	0.170	0.250	0.006	0.010
D	4.700	5.100	0.185	0.200
E	3.800	4.000	0.150	0.157
E1	5.800	6.200	0.228	0.244
e	1.27 BSC		0.050 BSC	
L	0.400	1.270	0.016	0.050
theta	0°	8°	0°	8°

NOTES:

1. Body dimensions do not include mode flash or protrusion.
2. This drawing is subject to change without notice.

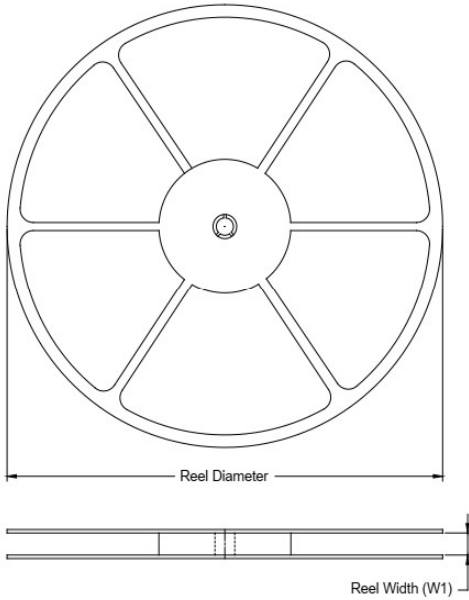
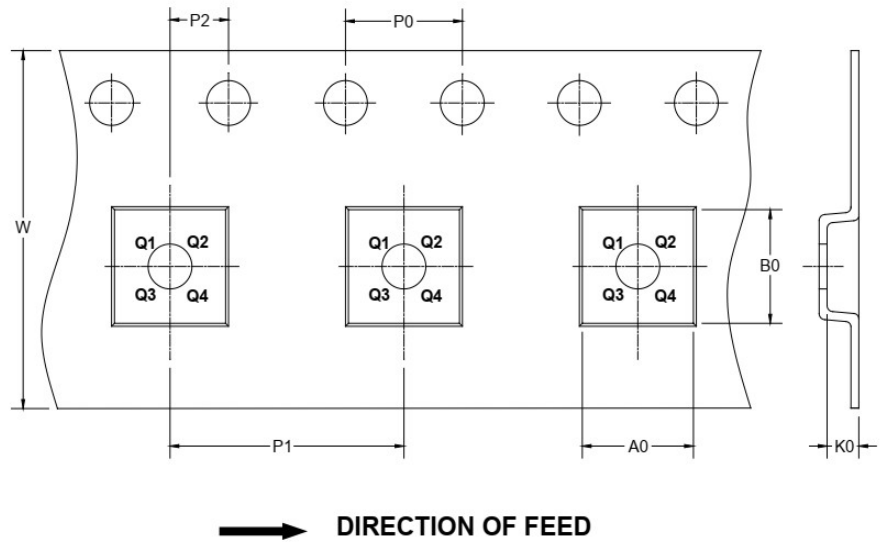
TAPE AND REEL INFORMATION
REEL DIMENSIONS

TAPE DIMENSIONS

NOTE: The picture is only for reference. Please make the object as the standard.

KEY PARAMETER LIST OF TAPE AND REEL

Package Type	Reel Diameter	Reel Width W1	A0	B0	K0	P0	P1	P2	W	Pin1
		(mm)	(mm)	(mm)	(mm)	(mm)	(mm)	(mm)	(mm)	Quadrant
SOIC-8	13"	12.4	6.40	5.40	2.10	4.0	8.0	2.0	12.0	Q1
MSOP-8	13"	12.4	5.20	3.30	1.50	4.0	8.0	2.0	12.0	Q1
TSSOP-8	13"	12.4	6.76	3.30	1.80	4.0	8.0	2.0	12.0	Q1

Low distortion, Low-noise, High Voltage Dual Operational Amplifiers

Conditions of Soldering and Storage

• Recommended condition of reflow soldering

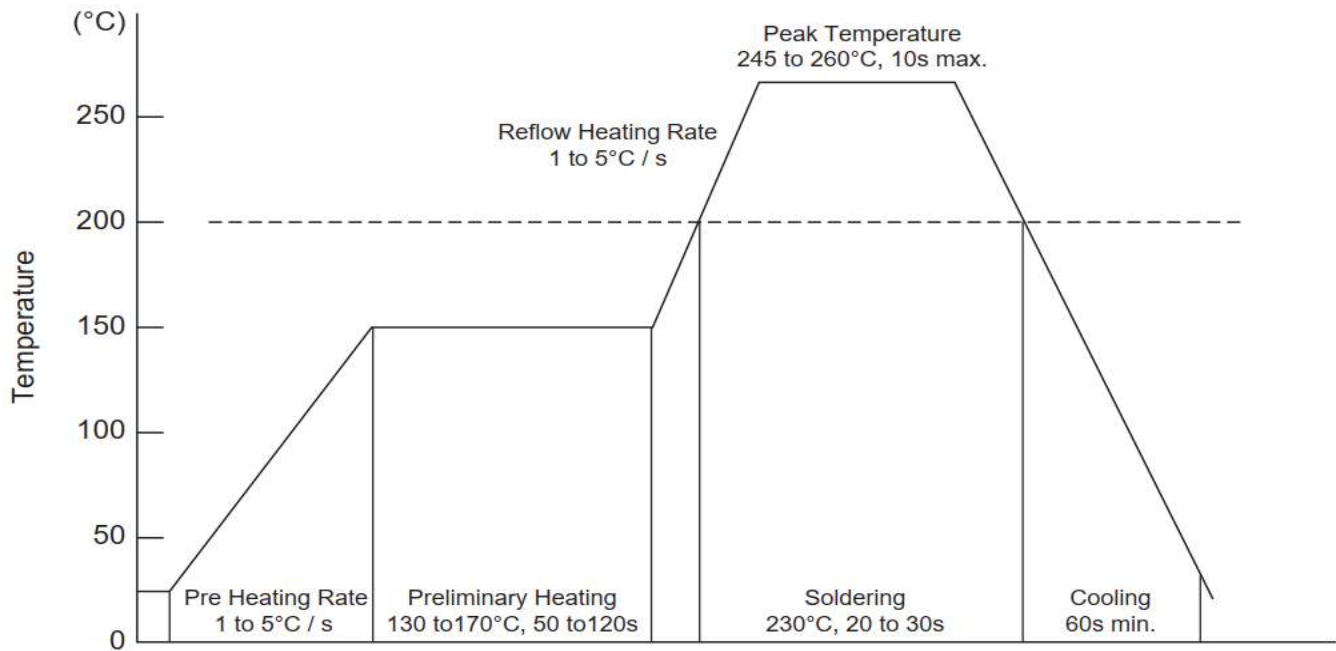

Recommended peak temperature is over 245°C, if peak temperature is below 245°C, you may adjust the following parameters:

- * Time length of peak temperature (longer)
- * Time length of soldering (longer)
- * Thickness of solder paste (thicker)

• Conditions of hand soldering

- * Temperature : 300°C
- * Time : 3s max
- * Times : one time

• Storage conditions

- * Temperature
5 to 40°C
- * Humidity
30 to 80% RH
- * Recommended period
One year after manufacturing