

40V, 250mA Low Dropout Voltage Linear Regulator

Features

- Input Voltage Range: 2.5V to 40V
- Quiescent Current: 2 μ A
- $\pm 1\%$ Output Accuracy
- 250mA Output Peak Current
- 100nA Disable Current
- Dropout Voltage: 0.35V at 100mA /V_{OUT} 5V
- Fixed Output Voltage 1.8V, 3.3V, 5V, 12V
- Adjustable Output Voltage Available by Specific Application
- Stable with Ceramic or Tantalum Capacitor
- Current Limit Protection
- Over-Temperature Protection
- Totally Lead-Free & Fully RoHS Compliant

Applications

- Portable, Battery Powered Equipment
- Low Power Microcontrollers
- Wireless Communication Equipment
- Laptop, Palmtops and PDAs
- Audio/Video Equipment
- Car Navigation Systems
- Industrial Controls and Home Automation
- Weighting Scales and Meters

General Description

The HCR2449 series are a group of low-dropout (LDO) voltage regulators offering the benefits of wide input voltage range, low dropout voltage, low power consumption, and miniaturized packaging.

Quiescent current of only 2 μ A makes these devices ideal for powering the battery-powered, always-on systems that require very little idle-state power dissipation to a longer service life. There is a shutdown mode by pulling the EN pin low. The shutdown current in this mode goes down to only 100nA(typical)

The HCR2449 series of linear regulators are stable with the ceramic output capacitor over its wide input range from 2.5V to 40V and the entire range of output load current from 0mA to 250mA.

The HCR2449 series is available in Green SOT-23-5 and DFN2x2-6L package. It is specified over the extended -40°C to +85°C temperature range.

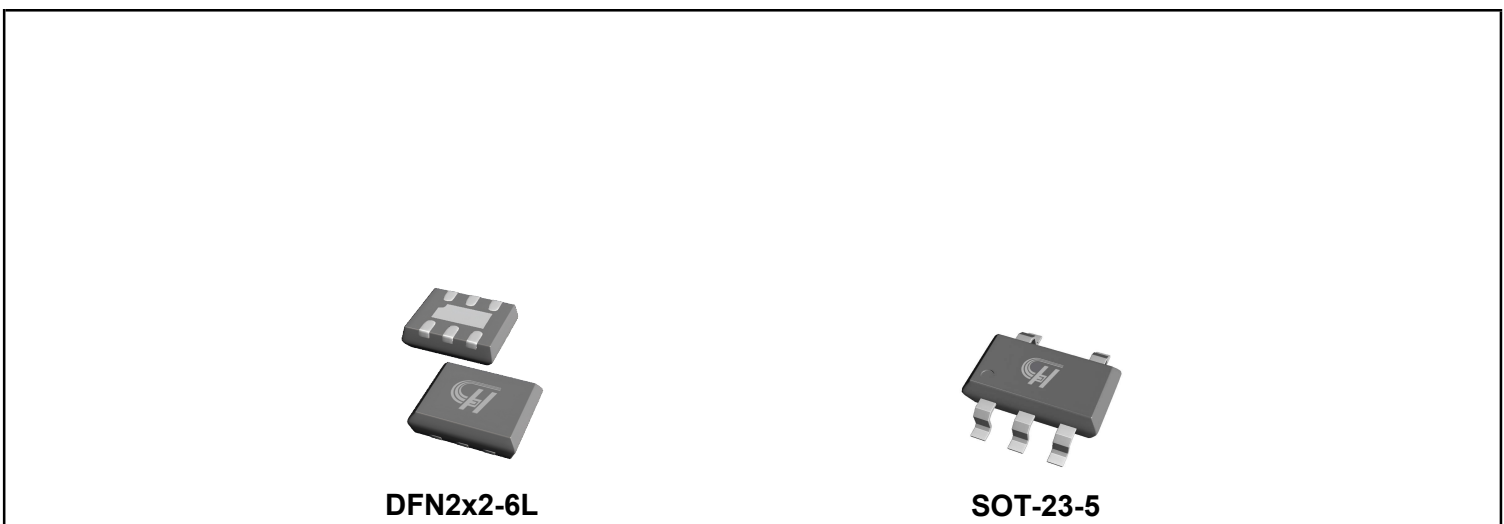

Figure 1. Package Type of HCR2449

40V, 250mA Low Dropout Voltage Linear Regulator
Function Block Diagram

Figure 5. Fixed and Adjustable Voltage Output Version

Ordering Information

Standard	Marking ^[2]	Voltage	Package	MSL Level ^[3]	Shipping
HCR2449-ADJM5TR	AAIG**	ADJ Voltage	SOT-23-5	MSL3	3000, Tape&Reel
HCR2449-1V8M5TR	AAIE**	1.8V	SOT-23-5	MSL3	3000, Tape&Reel
HCR2449-3V3M5TR	AAIF**	3.3V	SOT-23-5	MSL3	3000, Tape&Reel
HCR2449-5V0M5TR	AAIK**	5.0V	SOT-23-5	MSL3	3000, Tape&Reel
HCR2449-12V0M5TR	AAII**	12V	SOT-23-5	MSL3	3000, Tape&Reel
HCR2449-ADJN26LTR	AA2G**	ADJ Voltage	DFN2x2-6L	MSL3	3000, Tape&Reel
HCR2449-1V8N26LTR	AA2E**	1.8V	DFN2x2-6L	MSL3	3000, Tape&Reel
HCR2449-3V3N26LTR	AA2F**	3.3V	DFN2x2-6L	MSL3	3000, Tape&Reel
HCR2449-5V0N26LTR	AA2K**	5.0V	DFN2x2-6L	MSL3	3000, Tape&Reel
HCR2449-12V0N26LTR	AA2I**	12V	DFN2x2-6L	MSL3	3000, Tape&Reel

Note [2]: the "***" is date code

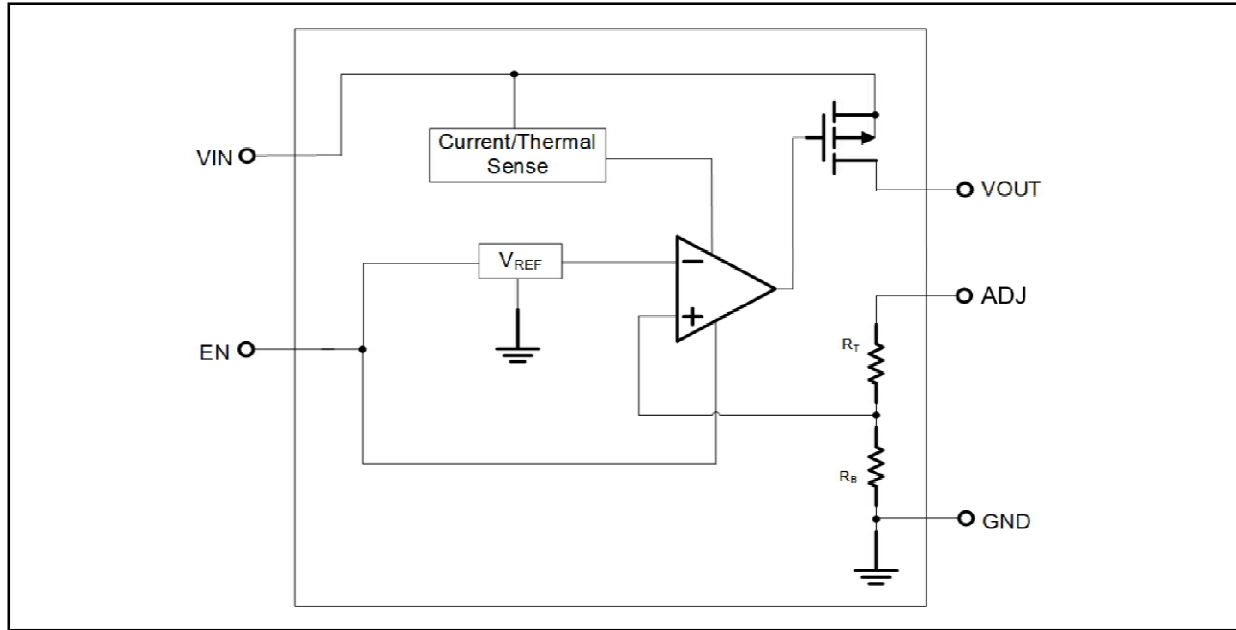
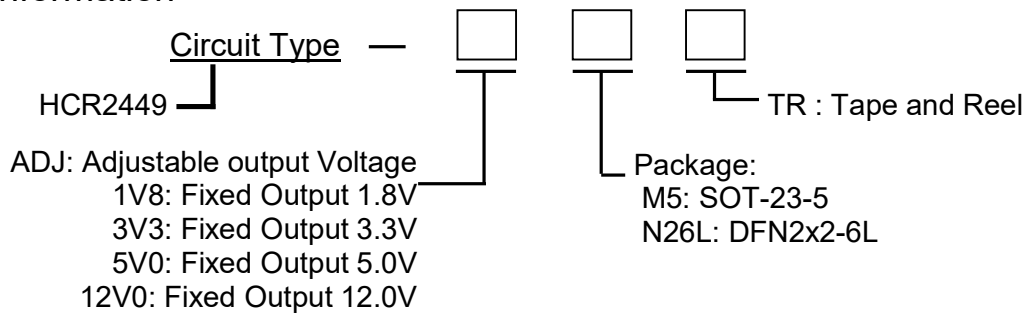
[3]: HCRSEMI classify the MSL level with using the common preconditioning setting in our assembly factory conforming to the JEDEC industrial standard J-STD-20F. Please align with HCRSEMI if your end application is quite critical to the preconditioning setting or if you have special requirement.

40V, 250mA Low Dropout Voltage Linear Regulator
Pin Configuration

Figure 2. Pin Configuration of HCR2449 (Top View)

Pin Description

SOT23-5	DFN2x2-6L	Pin Name	Pin Function
1	1	VIN	Power Input Voltage. From 2.5V to 40V input Voltage. At least 1uF supply bypass capacitor is recommended.
2	3	GND	Ground
3	2	EN	Chip Enable(Active High). Note that this pin is high impedance
4	4	ADJ	Feedback Pin (adjustable voltage version only, $V_{FB}=1.8V$). Connect this pin to the midpoint of an external resistor divider to adjustable the output voltage(Notes : $V_{OUT} = (R1 + R2) / R2 \times 1.8V$, And $R2 < 36K\Omega$)
4	4	NC	No internal Connection
5	6	VOUT	Regulated Output. Recommended output capacitor range:1uF to 10uF.
	5	NC	No internal Connection
-	Exposed(7)	SGND	Substrate of Chip. Leave floating or tie to GND.

Typical Application^[1]

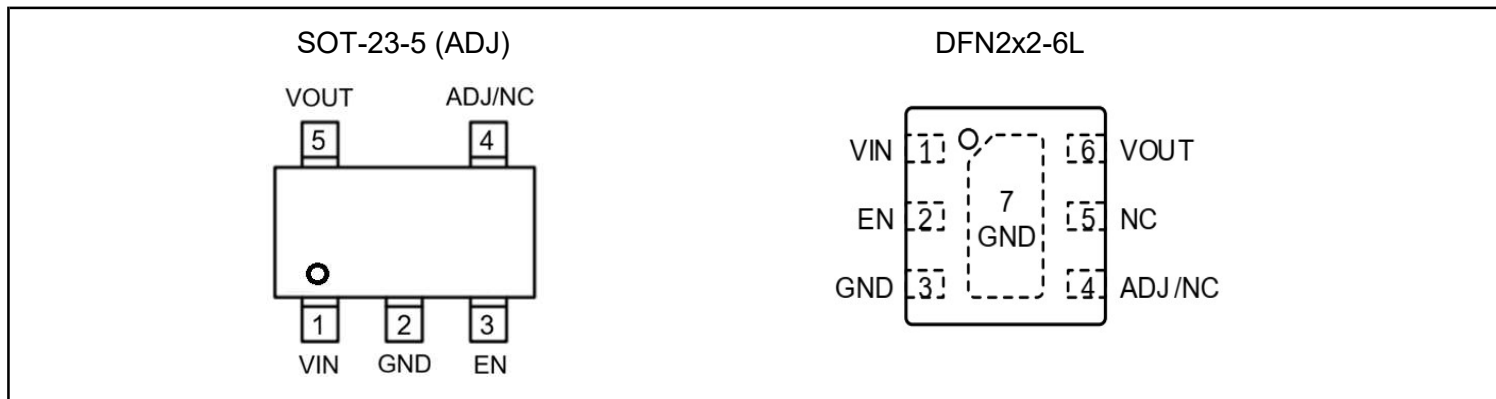
-- HCR2449 Fixed Version for SOT-23-5 and DFN2x2-6L packing

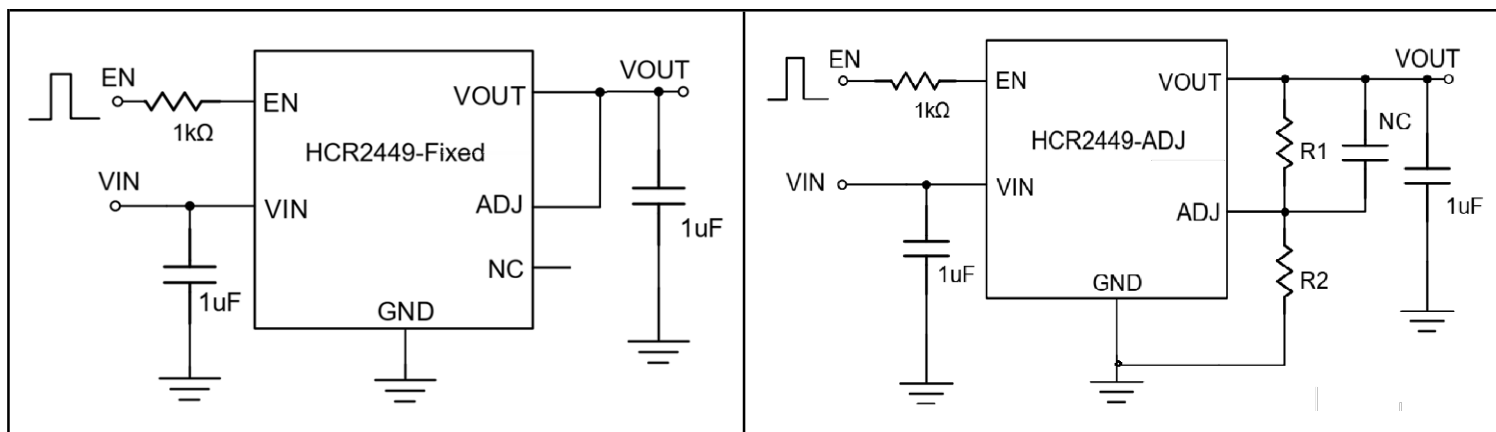

Figure 3. Fixed Voltage Output Version

 Figure 4. Adjustable Voltage Output Version^[2]

 Note 1. Input capacitor($C_{IN}=1\mu F$) and Output capacitor($C_{OUT}=10\mu F$) are recommended in all application circuit.

 2. $V_{OUT} = (R1 + R2) / R2 \times 1.8V$, And $R2 < 36K\Omega$

40V, 250mA Low Dropout Voltage Linear Regulator
Absolute Maximum Ratings ^{Note 4}

Parameter		Symbol	Value		Unit
Supply Input Voltage	V _{IN} , EN to GND	V _{IN}	-0.3 ~ +40		V
	ADJ to GND Voltage		-0.3 ~ +6		
	V _{OUT} to GND Voltage		-0.3 ~ +14		
	V _{OUT} to V _{IN} Voltage		-40 ~ +0.3		
Output Current		I _{OUT}	Internally Limited		-
Power Dissipation ^{note5}		P _D	SOT-23-5	500	mW
			DFN2x2-6L	1050	mW
Thermal Resistance (Junction to Ambient)		θ _{JA}	SOT-23-5	220	°C/W
			DFN2x2-6L	95	°C/W
Junction Temperature		T _{J(Max)}	150		°C
Operating Ambient Temperature		T _a	-40 ~ +85		°C
Storage Temperature Range		T _{STG}	-40 ~ +150		°C
Lead Temperature(Soldering, 10sec)		T _{LEAD}	260		°C
Human Body Model		HBM	2000		V
Charged Device Model		MM	200		V

Note 4: Stresses beyond those listed under Absolute Maximum Ratings may cause permanent damage to the device.

There are stress ratings only, and functional operation of the device at these conditions is not implied.

Exposure to absolute-maximum-rated conditions for extended period may affect device reliability.

5: Ratings apply to ambient temperature at +25°C. The JEDEC STD.51 High-K board design used to derive this data was a 3inch x3 inch multilayer, board with 1oz. Internal power and ground planes and 2oz. Copper on the top and bottom of the board.

Recommended Operating Conditions

Parameter	Symbol	Min	Max	Unit
Supply Input Voltage	V _{IN}	2.5	36	V
Junction Temperature Range	T _J	-40	+125	°C
Operating Ambient Temperature	T _a	-40	+85	°C

40V, 250mA Low Dropout Voltage Linear Regulator
Electrical Characteristics

(VIN =15V, VEN =5V, TA=25oC unless otherwise specified)

Parameter	Symbol	Condition	Min	Type	Max	Unit
Input Voltage	VIN	-	2.5	-	36	V
Output Voltage	VOUT	VOUT=1.8V/3.3V/5V/12V as reference, VIN=15V, IOUT=1mA	VOUT X 99%	-	VOUT X 101%	V
Dropout Voltage (ILOAD=100mA)	VDROP	VOUT>=5V	-	0.35	-	V
	VDROP_3.3V	VOUT=3.3V	-	0.38	-	
	VDROP_1.8V	VOUT=1.8V	-	0.46	-	
Quiescent Current (ILOAD=0mA)	IQ	VOUT<=5V	-	2.0	-	uA
	IQH	5V<VOUT<=12V	-	3.5	-	uA
Shutdown Ground Current	ISD	VEN=0V, VOUT=0V	-	0.1	0.5	uA
ADJ Input Current	IADJ	ADJ=VOUT, VOUT<=5V	-	0.6	-	uA
Line Regulation	ΔVLINE	ILOAD=1mA, 10V<=VIN<=20V	-	0.8	-	%
Load Regulation	ΔVLOAD	10mA<=ILOAD<=0.1A	-	0.5	-	%
Output Current Limit	ILIM	VOUT=0	250	350	-	mA
Enable Threshold Voltage	VIH	EN Rising	1.1	-	-	V
	VIL	EN Falling	-	-	0.4	
EN Input Current	IEN	VEN=24V	-	10	100	nA
Power Supply Rejection Ration	PSRR	VOUT=3.3V, ILOAD=30mA, VIN=12V, f=1KHz	-	70	-	dB
THERMAL PROTECTION						
Thermal Shoutdown Temperature	TSD	Shutdown, Temp increasing	-	160	-	'C
Thermal Shoutdown Hysteresis	ΔTSHDN		-	30	-	'C

Note 3. The dropout voltage difference is the voltage difference between the input and output, where the output voltage is 2% lower than its nominal value.

40V, 250mA Low Dropout Voltage Linear Regulator

Typical Performance Characteristics

Test Condition: $T_a=25^\circ\text{C}$, $I_{out}=1\text{mA}$, $C_{out}=10\mu\text{F}$, unless otherwise noted

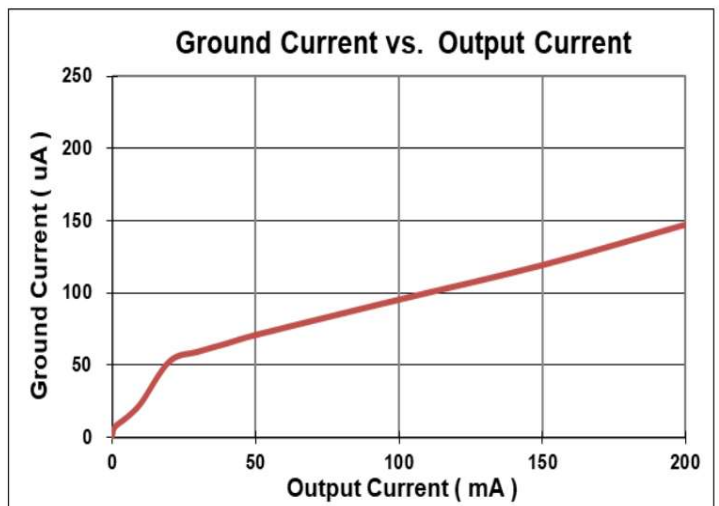
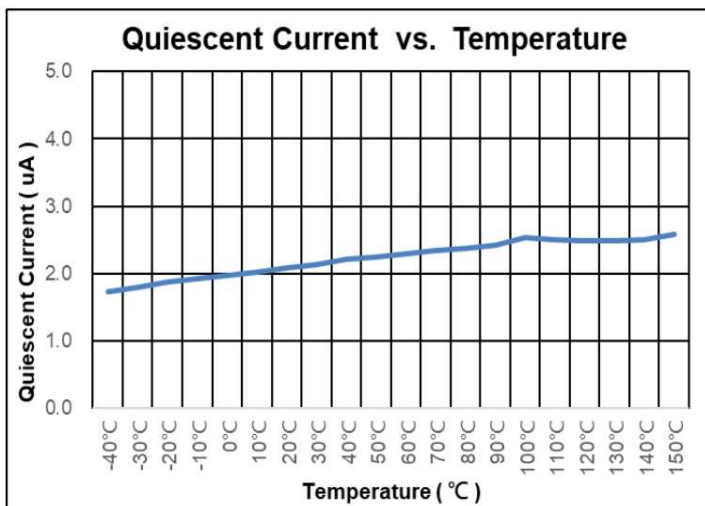
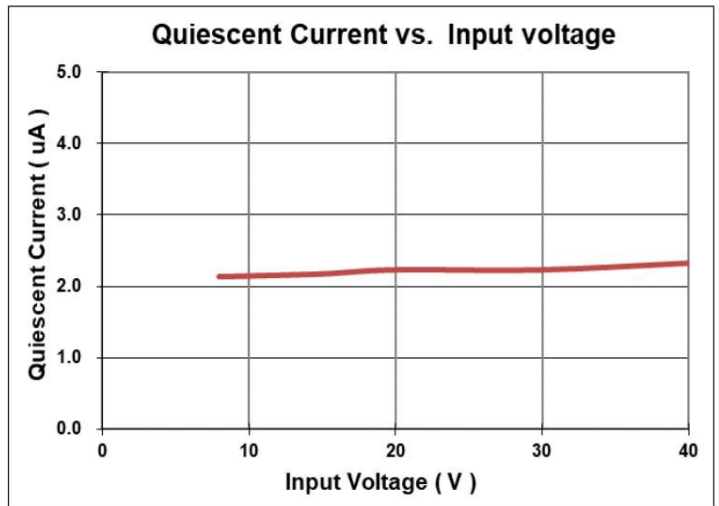
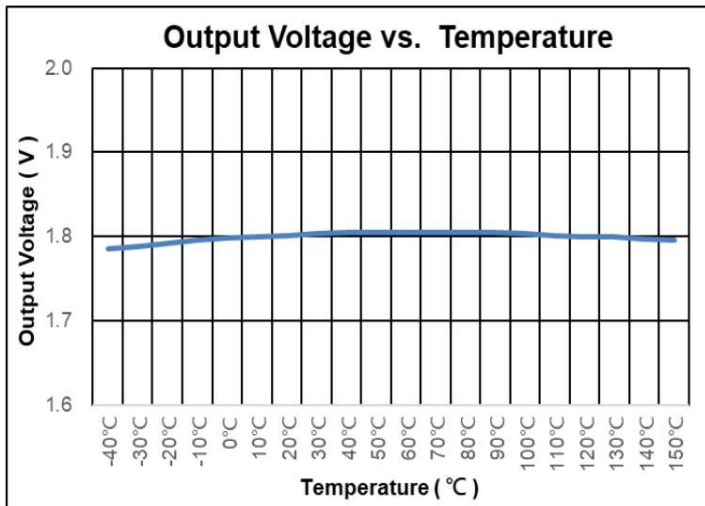
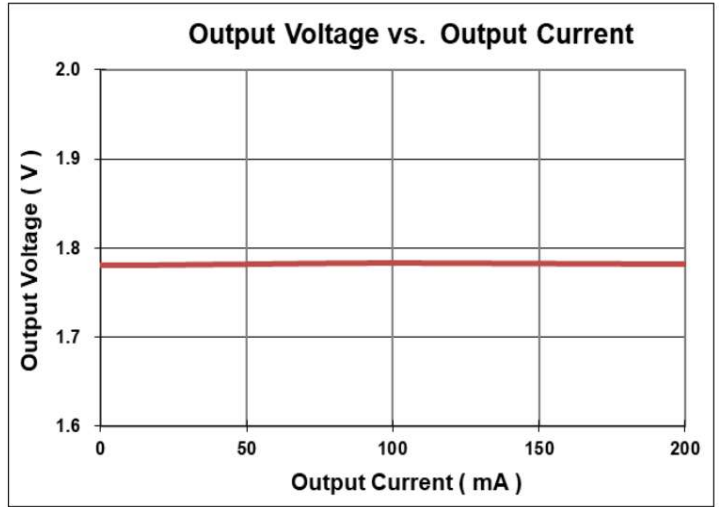
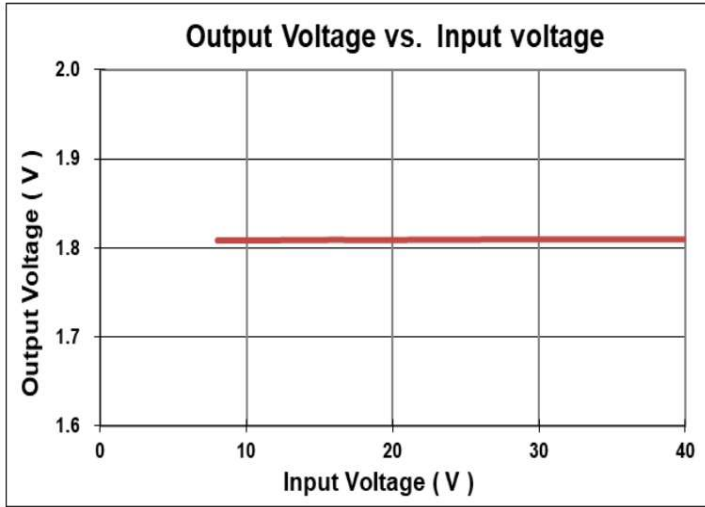

40V, 250mA Low Dropout Voltage Linear Regulator

Typical Performance Characteristics(Con.)

Test Condition: Ta=25°C, Iout=1mA, Cout=10uF, unless otherwise noted

Load Transient Response



Line Transient Response

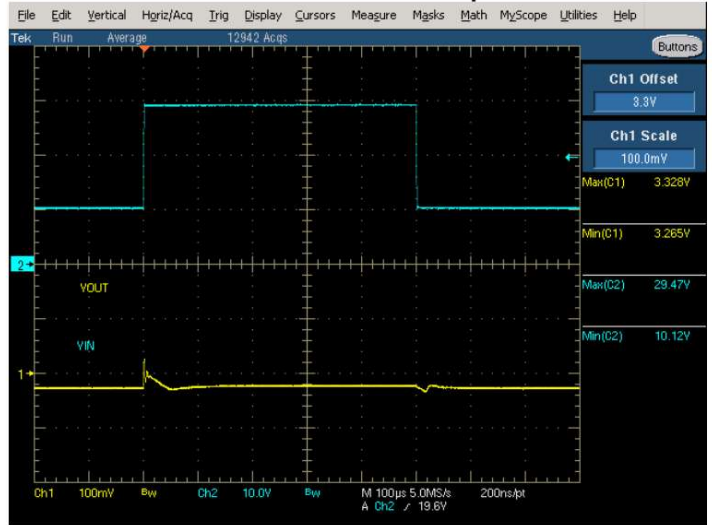

Current Limit

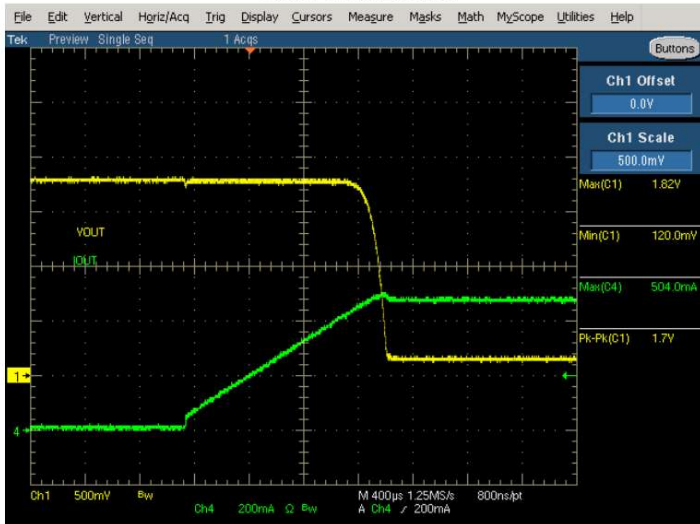

Power On

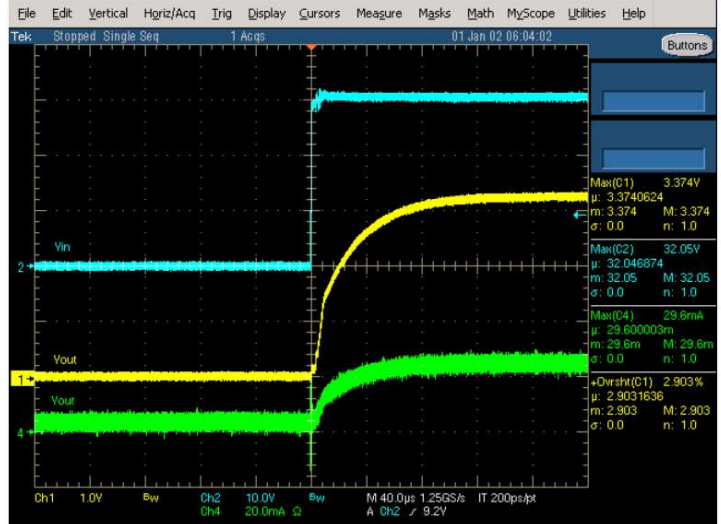

PSRR

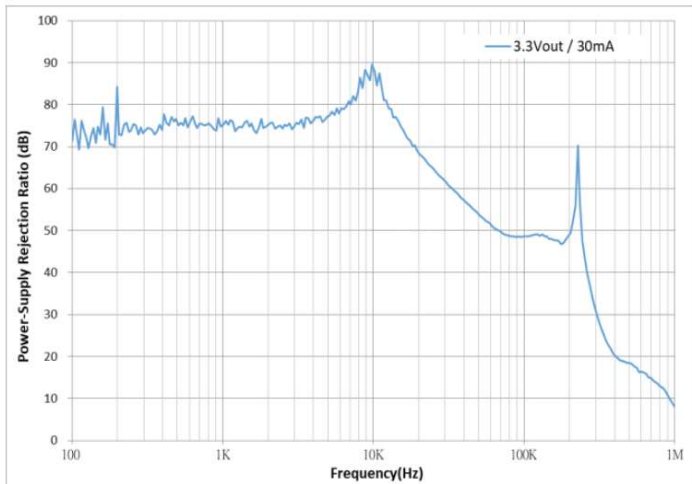

40V, 250mA Low Dropout Voltage Linear Regulator

Applications Information

Input and Output Capacitor Requirements

The external input and output capacitors of HCR2449 series must be properly selected for stability and performance. Use a 1μF or larger input capacitor and place it close to the IC's VIN and GND pins. Any output capacitor meeting the minimum 1mΩ ESR (Equivalent Series Resistance) and effective capacitance between 1μF and 22μF requirement may be used. Place the output capacitor close to the IC's VOUT and GND pins. Increasing capacitance and decreasing ESR can improve the circuit's PSRR and line transient response.

Current Limit

The HCR2449 series contain the current limiter of output power transistor, which monitors and controls the transistor, limiting the output current to 350mA (typical). The output can be shorted to ground indefinitely without damaging the part.

Dropout Voltage

The HCR2449 series use a PMOS pass transistor to achieve low dropout. When (VIN – VOUT) is less than the dropout voltage (VDROP), the PMOS pass device is in the linear region of operation and the input-to-output resistance is the RDS(ON) of the PMOS pass element. VDROP scales approximately with the output current because the PMOS device behaves as a resistor in dropout condition.

As any linear regulator, PSRR and transient response are degraded as (VIN – VOUT) approaches dropout condition.

Adjustable Output Voltage Application

HCR2449 with ADJ pin also can work as an adjustable output voltage LDO. Figure 2 gives the connections for the adjustable output voltage application. The resistor divider from VOUT to ADJ sets the output voltage when in regulation.

The voltage on the ADJ pin sets the output voltage and

is determined by the values of R1 and R2. In order to keep a good temperature coefficient of output voltage, the values of R1 and R2 should be selected carefully to ignore the temperature effect of input current at the ADJ pin. A current greater than 50μA in the resistor divider is recommended to meet the above requirement. The adjustable output voltage can be calculated using the formula given in equation 1:

$$V_{OUT} = \frac{R1+R2}{R2} \times V_{ADJ} \quad (1)$$

where VADJ is determined by the output voltage selections in the ordering information of HCR2449-1V8. The maximum adjustable output voltage is 5V. Generally, to maximize the available adjustable output voltage range, HCR2449-1V8M5 is recommended (VADJ is 1.8V in formula 1 now).

The minimum recommended 50μA in the resistor divider makes the application no longer a 2μA low quiescent LDO.

OTP (Over Temperature Protection)

The over temperature protection function of HCR2449 series will turn off the P-MOSFET when the junction temperature exceeds 160°C (typ.). Once the junction temperature cools down by approximately 30°C, the regulator will automatically resume operation.

Thermal Application

For continuous operation, do not exceed the absolute maximum junction temperature. The maximum power dissipation depends on the thermal resistance of the IC package, PCB layout, rate of surrounding airflow, and difference between junction and ambient temperature. The maximum power dissipation can be calculated as below:

TA=25°C, HCR-SEMI PCB

The Max PD(Max) = (125°C - 25°C) / (220°C/W) = 0.45W for SOT-23-5 packages.

40V, 250mA Low Dropout Voltage Linear Regulator

Applications Information(Con.)

Thermal Application(con.)

The Max PD(Max) $= (125^{\circ}\text{C} - 25^{\circ}\text{C}) / (95^{\circ}\text{C}/\text{W}) = 1.05\text{W}$
for DFN2x2-6L packages.

Power dissipation (PD) is equal to the product of the output current and the voltage drop across the output pass element, as shown in the equation below:

$$\text{PD} = (\text{VIN} - \text{VOUT}) \times \text{IOUT}$$

Layout Consideration

By placing input and output capacitors on the same side

of the PCB as the LDO, and placing them as close as is practical to the package can achieve the best performance. The ground connections for input and output capacitors must be back to the HCR2449 ground pin using as wide and as short of a copper trace as is practical.

Connections using long trace lengths, narrow trace widths, and/or connections through via must be avoided. These add parasitic inductances and resistance that results in worse performance especially during transient conditions.

40V, 250mA Low Dropout Voltage Linear Regulator
Package Outline Dimensions

SOT-23-5 (M5)

Unit: mm

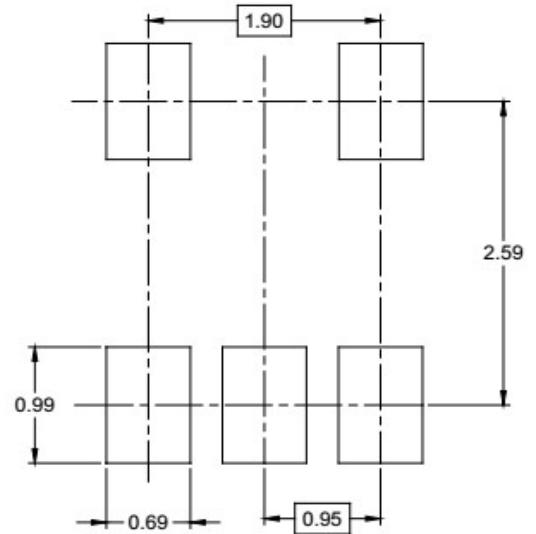
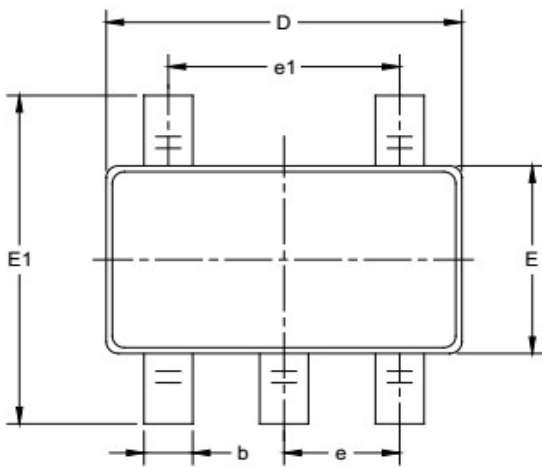
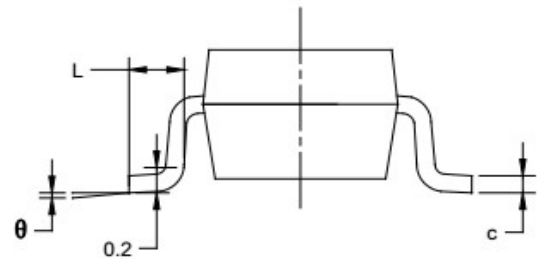
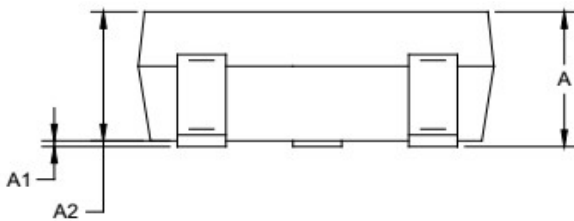

RECOMMENDED LAND PATTERN (Unit: mm)

Symbol	Dimensions In Millimeters		Dimensions In Inches	
	MIN	MAX	MIN	MAX
A	1.050	1.250	0.041	0.049
A1	0.000	0.100	0.000	0.004
A2	1.050	1.150	0.041	0.045
b	0.300	0.500	0.012	0.020
c	0.100	0.200	0.004	0.008
D	2.820	3.020	0.111	0.119
E	1.500	1.700	0.059	0.067
E1	2.650	2.950	0.104	0.116
e	0.950 BSC		0.037 BSC	
e1	1.900 BSC		0.075 BSC	
L	0.300	0.600	0.012	0.024
θ	0°	8°	0°	8°

40V, 250mA Low Dropout Voltage Linear Regulator
Package Outline Dimensions(con.)

DFN2x2-6L (N26L)

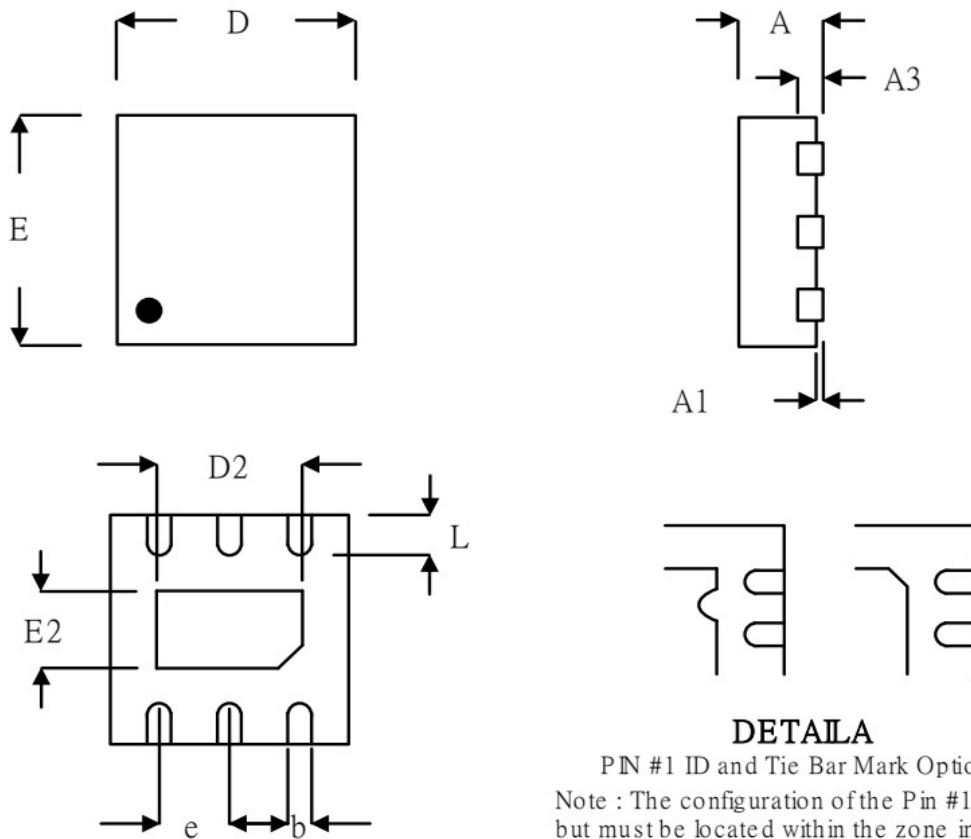
Unit: mm

DETAILA

PN #1 ID and Tie Bar Mark Options

Note : The configuration of the Pin #1 identifier is optional, but must be located within the zone indicated.

Symbol	Millimeters		Inches	
	Min.	Max.	Min.	Max.
A	0.700	0.800	0.028	0.031
A1	0.000	0.050	0.000	0.002
A3	0.175	0.250	0.007	0.010
b	0.200	0.350	0.008	0.014
D	1.950	2.050	0.077	0.081
D2	1.000	1.450	0.039	0.057
E	1.950	2.050	0.077	0.081
E2	0.500	0.850	0.020	0.033
e	0.650		0.026	
L	0.300	0.400	0.012	0.016

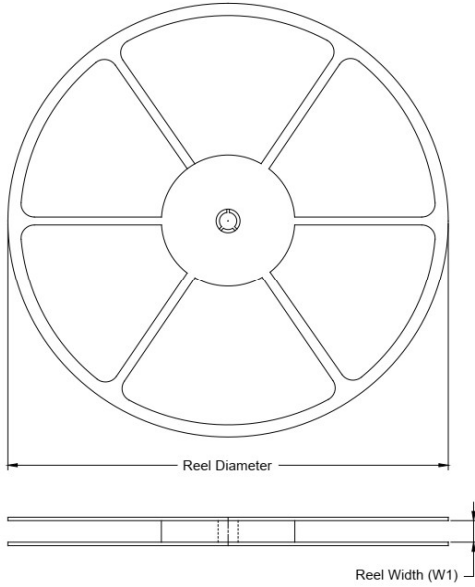
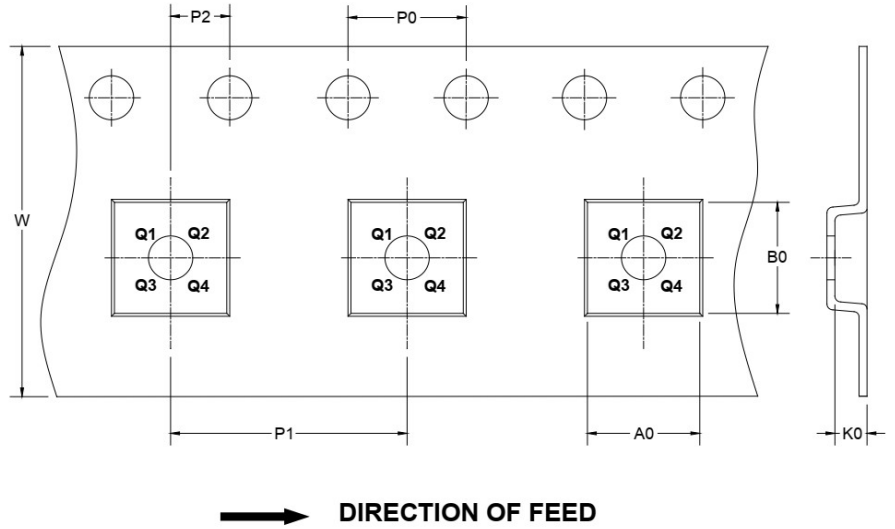
40V, 250mA Low Dropout Voltage Linear Regulator
TAPE AND REEL INFORMATION
REEL DIMENSIONS

TAPE DIMENSIONS

NOTE: The picture is only for reference. Please make the object as the standard.

KEY PARAMETER LIST OF TAPE AND REEL

Package Type	Reel Diameter	Reel Width W1 (mm)	A0 (mm)	B0 (mm)	K0 (mm)	P0 (mm)	P1 (mm)	P2 (mm)	W (mm)	Pin1 Quadrant
SOT-23-5	7"	9.5	3.20	3.20	1.40	4.0	4.0	2.0	8.0	Q3
DFN2x2-6L	7"	9.5	2.30	2.30	1.00	4.0	4.0	2.0	8.0	Q1

40V, 250mA Low Dropout Voltage Linear Regulator

Conditions of Soldering and Storage

• Recommended condition of reflow soldering

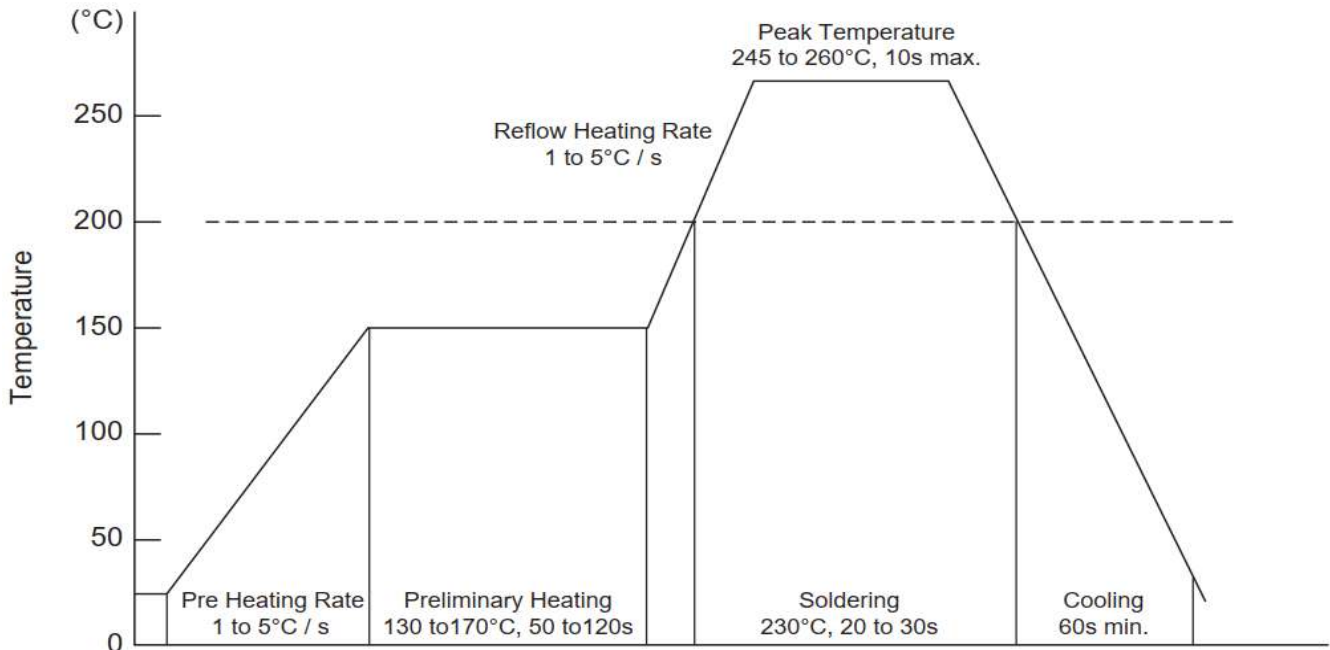

Recommended peak temperature is over 245°C, if peak temperature is below 245°C, you may adjust the following parameters:

- * Time length of peak temperature (longer)
- * Time length of soldering (longer)
- * Thickness of solder paste (thicker)

• Conditions of hand soldering

- * Temperature : 300°C
- * Time : 3s max
- * Times : one time

• Storage conditions

- * Temperature
5 to 40°C
- * Humidity
30 to 80% RH
- * Recommended period
One year after manufacturing