

Low-noise JFET Quad Operational Amplifier**Features**

- Wide common-mode (up to VCC+) and differential voltage range
- Low input bias and offset current
- Low noise $V_n=15nV/\sqrt{\text{Hz}}$ (typ) at 1KHz
- Output short-circuit protection
- High input impedance JFET input stage
- Internal frequency compensation
- Latch up free operation
- High slew rate: 16 V/ μs (typical)
- Available in Green SOIC-14, DIP14 Packages
- Operating Temperature: -40°C to +85°C

Applications

- Motor Drives: AC and servo drive control and power stage modules
- Single phase online UPS
- Three phase UPS
- Pro audio mixers
- Battery test equipment

General Description

The HCR084C is high-speed, JFET input, quad operational amplifiers incorporating well matched, high voltage JFET and bipolar transistors in a monolithic integrated circuit.

The devices feature high slew rates, low input bias and offset currents, and low offset voltage temperature coefficient.

The HCR084C is available in green SOIC-14 (SOP-14) and DIP-14 packages, It is specified over the extended temperature range from -40°C to +85°C.

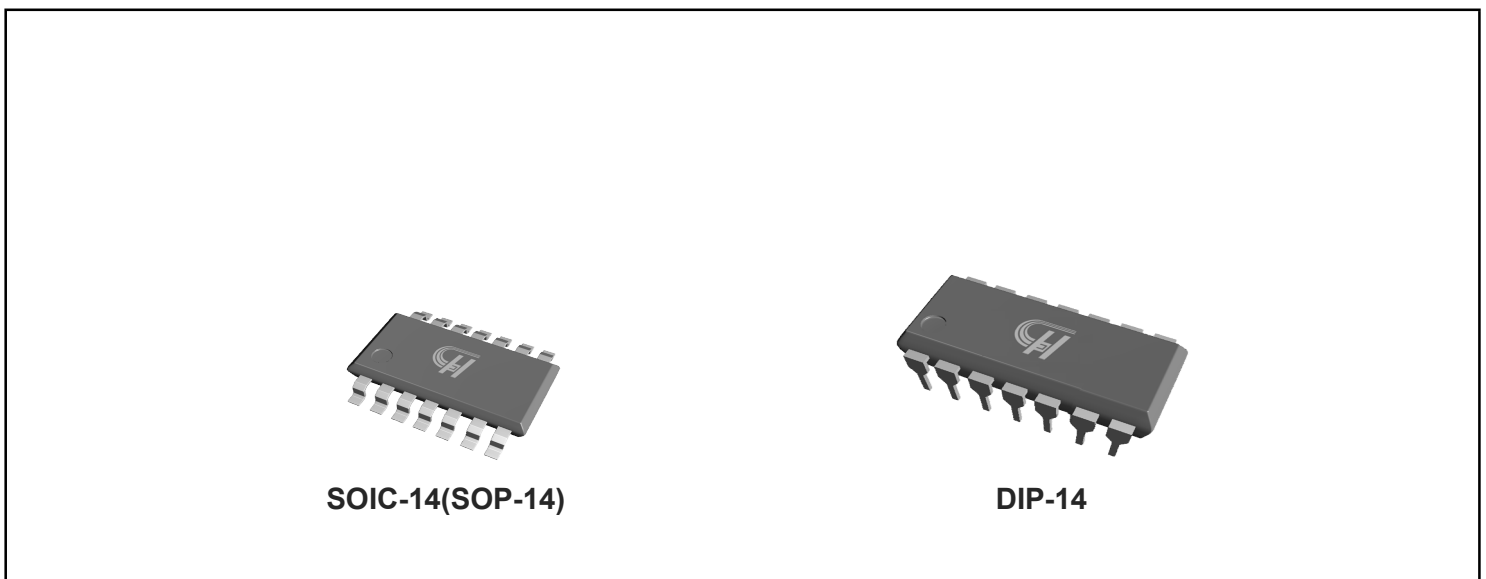


Figure 1. Package Type of HCR084C

Low-noise JFET Quad Operational Amplifier

Pin Configuration

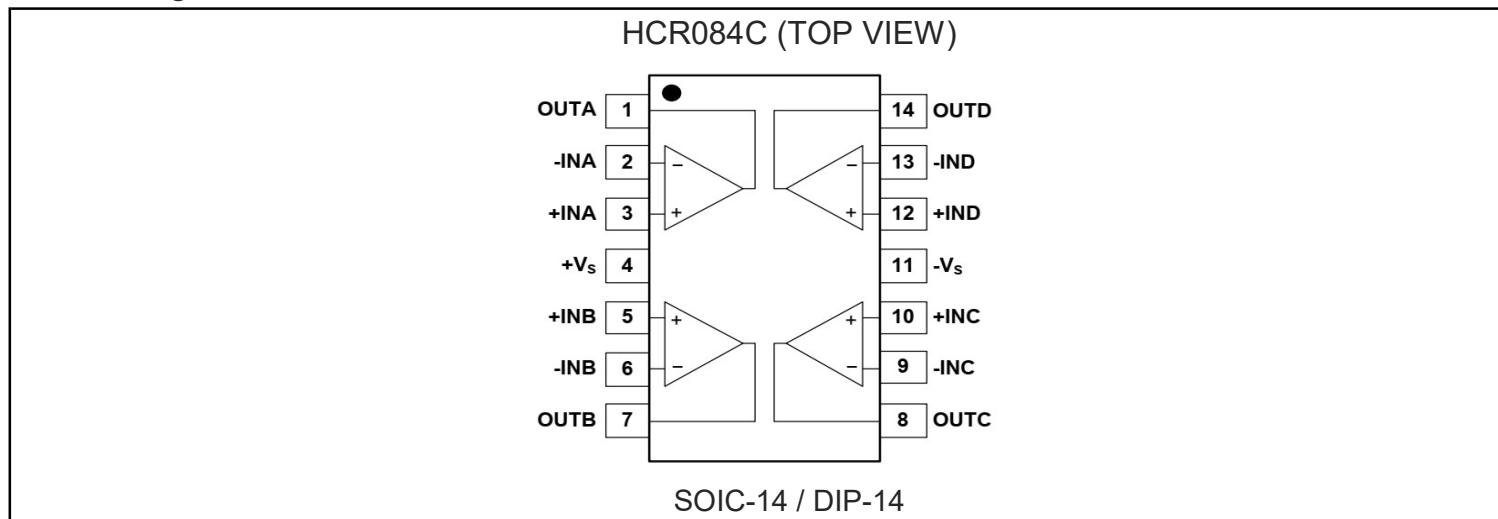


Figure 2. Pin Configuration of HCR084C (Top View)

Pin Function Table

Name	Function
+INA, +INB, +INC, +IND	Non-inverting Inputs
-INA, -INB, -INC, -IND	Inverting Inputs
+Vs	Positive Power Supply
-Vs	Negative Power Supply
OUTA, OUTB, OUTC, OUTD	Outputs

Typical Applications

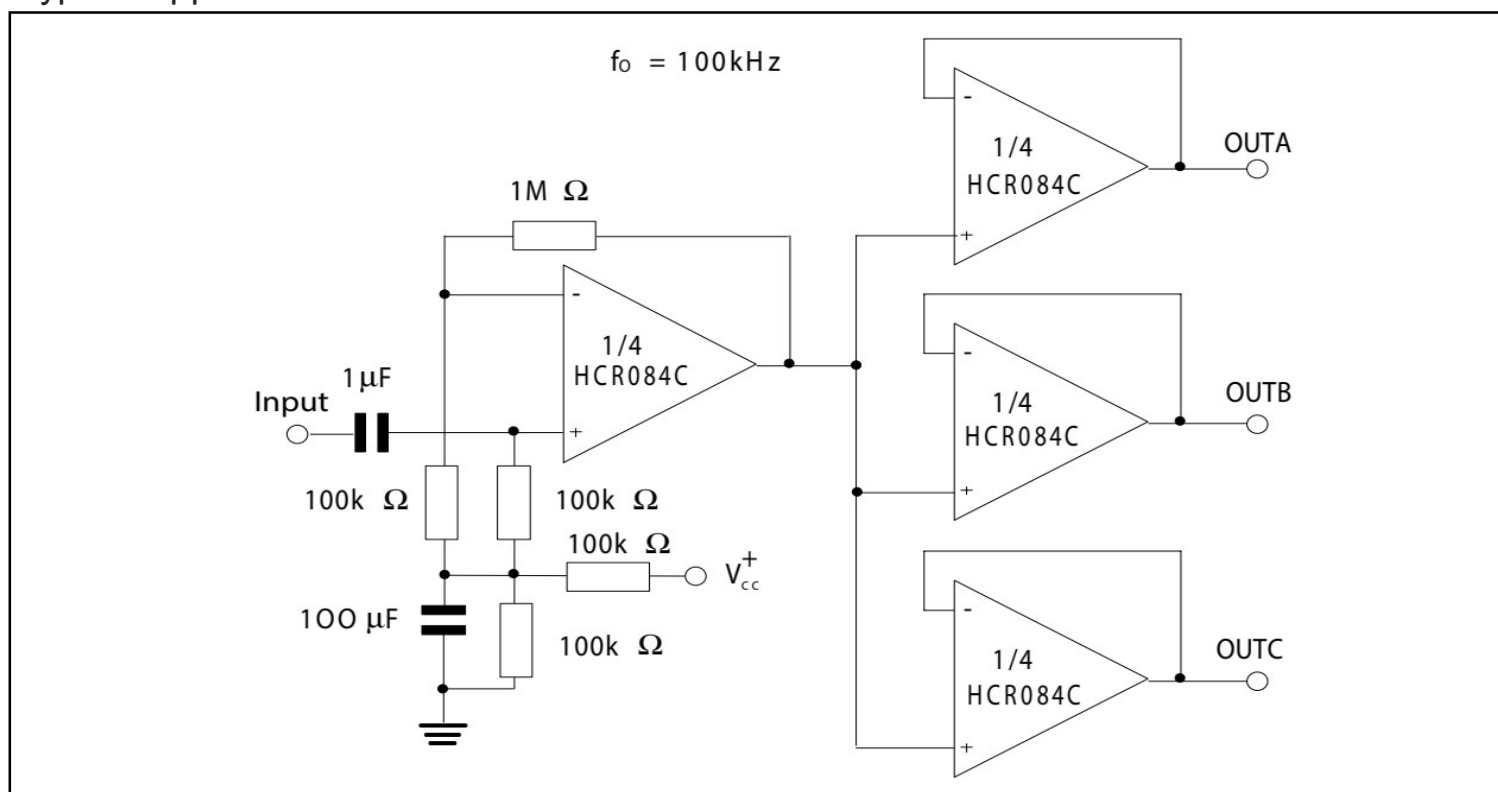
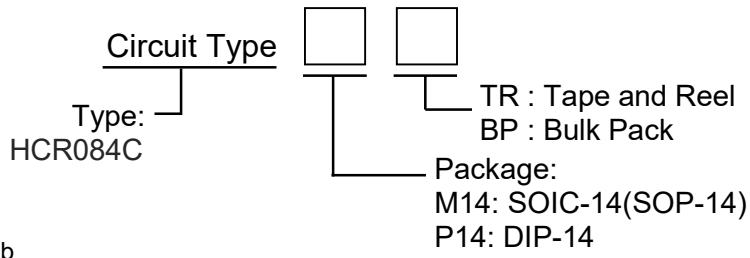


Figure 3. Audio Distribution Amplifier

Low-noise JFET Quad Operational Amplifier

Ordering Information



Ordering Code ^{note b}

Part Number	Marking ID	Temperature Range	Package	Package Type
HCR084CM14TR	HCR084CMXX	-40°C to +85°C	SOIC-14 (SOP-14)	2500pcs/TR
HCR084CP14BP	HCR084CPXX	-40°C to +85°C	DIP-14	2000pcs/Box

note b: The "XX" is date code.

Functional Block Diagram

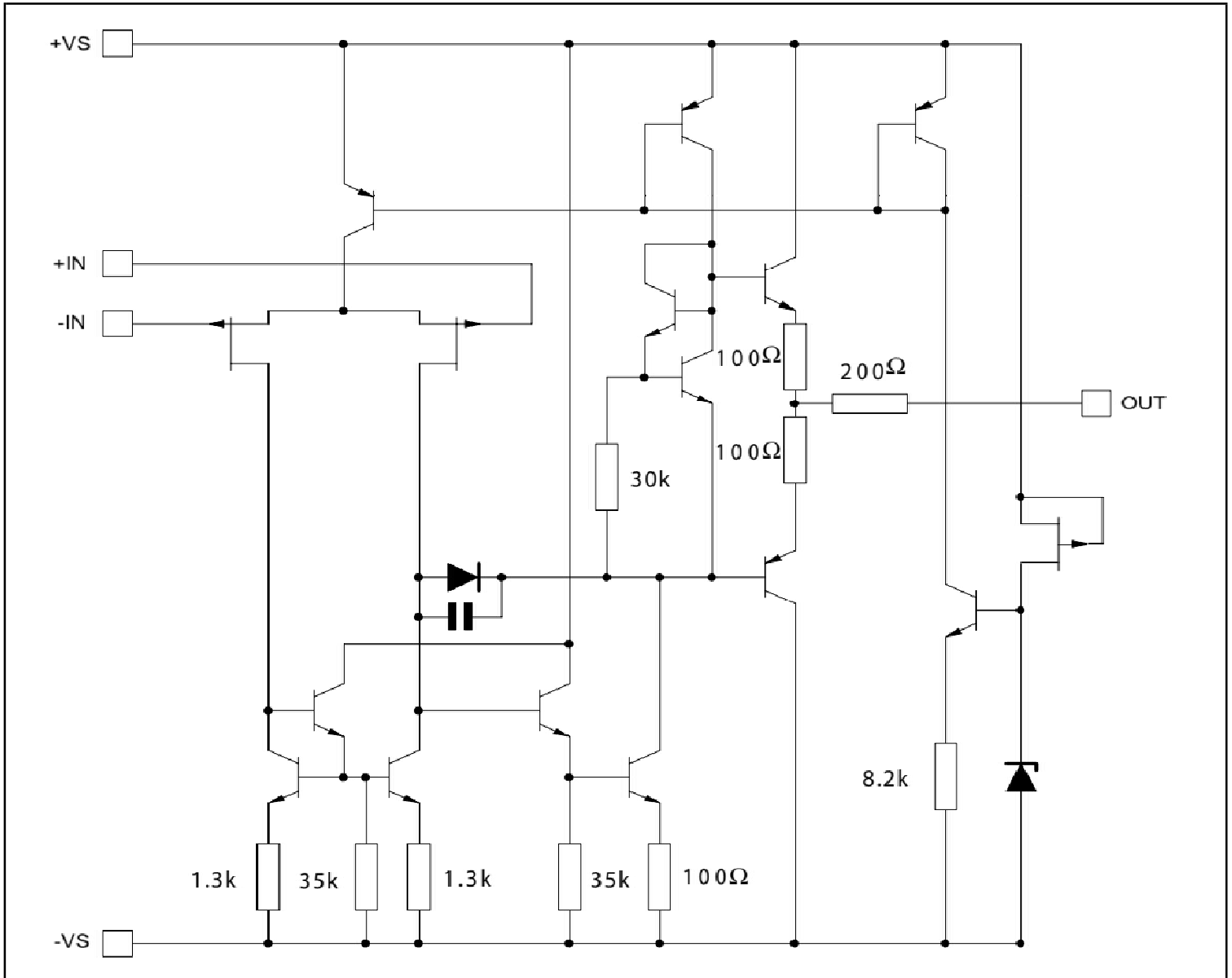


Figure 4. Functional Block Diagram

Low-noise JFET Quad Operational Amplifier

Absolute Maximum Ratings

Parameter		Symbol	Value	Unit
Supply Voltage ^{note1}		VCC	±18	V
Input Voltage ^{note2}		Vi	±15	V
Differential Input Voltage ^{note3}		Vid	±30	V
Total Power Dissipation	SOIC-14	Ptot	680	mW
	DIP-14		710	mW
Storage Temperature Range		TSTG	-65 to 150	'C
Operating Temperature Range		Toper	0 to +70	'C
Junction Temperature		TJ	150	'C
Lead Temperature (Soldering, 10s)		TLEAD	260	'C
Thermal Resistance (Junction to Ambient) ^{note4,5}	SOIC-14	θJA	105	'C/W
	DIP-14		86	'C/W
Thermal Resistance (Junction to Case) ^{note4,5}	SOIC-14	θJC	31	'C/W
	DIP-14		26	'C/W
Output- Short-circuit duration ^{note6}		-	infinite	-
HBM: human body mode		ESD	1.0	KV
MM: machine mode			200	V
CDM charged device mode			1.5	KV

Note 1. All voltage values, except differential voltage, are with respect to the zero reference level (ground) of the supply voltages where the zero reference level is the midpoint between VCC+ and VCC-.

2. The magnitude of the input voltage must never exceed the magnitude of the supply voltage or 15 volts, whichever is less.
3. Differential voltages are the non-inverting input terminal with respect to the inverting input terminal.
4. Short-circuits can cause excessive heating. Destructive dissipation can result from simultaneous short-circuits on all amplifiers.
5. θJA and θJC are typical values.
6. The output may be shorted to ground or to either supply. Temperature and/or supply voltages must be limited to ensure that the dissipation rating is not exceeded.

Recommended Operating Conditions

Parameter	Symbol	Min.	Max.	Unit
Supply Voltage	VCC	6.0	36	V
Operating free-air temperature range	Toper	0	+70	'C

Low-noise JFET Quad Operational Amplifier
Electrical Characteristics

 (T_{amb}=+25 °C, At V_{CC}=±15V, Unless Otherwise Specified.)

Parameter	Symbol	Conditions	Min	Type	Max	Unit
Input Offset Voltage	V _{OS}	V _O =1.4V, R _S =0Ω, V _{CC} =5V to 30V	-	3	10	mV
			-	-	13	
Input Offset Voltage Drift	ΔV _{OS} /ΔT	-	-	10	-	uV/°C
Input Offset Current	I _{IO}	T _{amb} =+25°C T _{min} ≤T _{amb} ≤T _{max}	-	10	100	pA
			-	-	4	nA
Input Bias Current ^[7]	I _{IB}	T _{amb} =+25°C T _{min} ≤T _{amb} ≤T _{max}	-	40	200	pA
			-	-	20	nA
Large Signal Voltage Gain	A _{vd}	R _L =2KΩ, V _O =±10V	25	200	-	V/mV
Supply Voltage Rejection Ratio	PSSR	R _S =50Ω	70	86	-	dB
Supply Current , no load	I _Q	T _{amb} =+25°C T _{min} ≤T _{amb} ≤T _{max}	-	1.4	2.5	mA
			-	-	2.5	
Input Common Mode Voltage Range	V _{CM}	-	±11	+15	-	V
				-12	-	
Common Mode Rejection Ratio (R _S =50Ω)	CMR	T _{amb} =+25°C T _{min} ≤T _{amb} ≤T _{max}	70	86	-	dB
			70	-	-	
Output Short Circuit Current to Ground	I _{Osc}	T _{amb} =+25°C	10	40	60	mA
Output Voltage Swing	±V _{opp}	T _{amb} =+25°C, R _L =2KΩ T _{amb} =+25°C, R _L =10KΩ T _{min} ≤T _{amb} ≤T _{max} , R _L =2KΩ T _{min} ≤T _{amb} ≤T _{max} , R _L =10KΩ	10	12	-	V
			12	13.5	-	
			10	28	-	
			12	-	-	
Slew Rate	SR	V _{in} =10V, R _L =2KΩ, C _L =100pF, unity gain	8	16	-	V/us
Rise time	t _r	V _{in} =20mV, R _L =2KΩ, C _L =100pF, unity gain	-	0.1	-	us
Gain Bandwidth Product	GBP	V _{in} =10mV, R _L =2KΩ, C _L =100pF, f=100KHz	2.5	4	-	MHz
Equivalent Input noise voltage	e _n	R _S =100Ω, f=KHz	-	15	-	nV/√Hz
Phase margin	Φ _m	-	-	45	-	degrees
Channel Separation	V _{O1} /V _{O2}	A _v =100	-	120	-	dB

Note [7].The input bias currents are junction leakage currents which approximately double for every 10°C increase in the junction temperature.

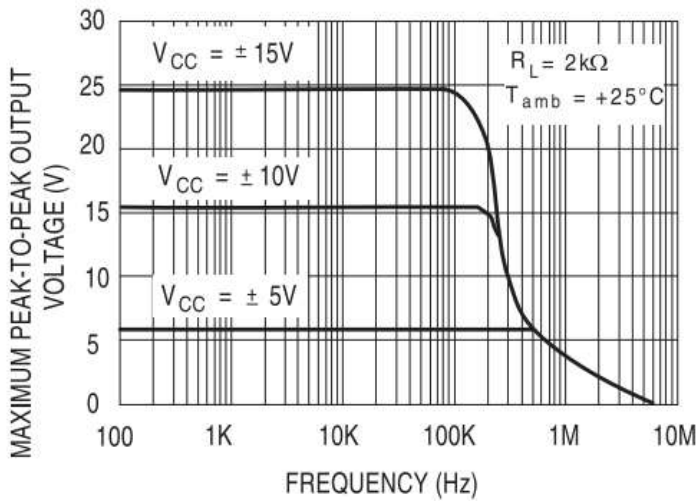
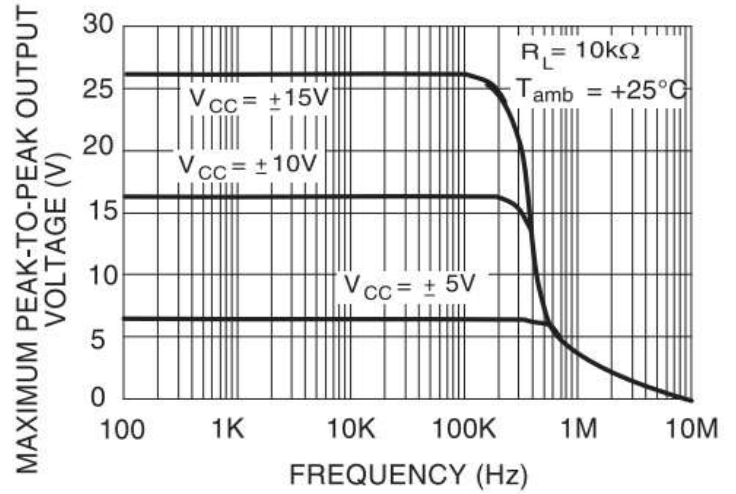
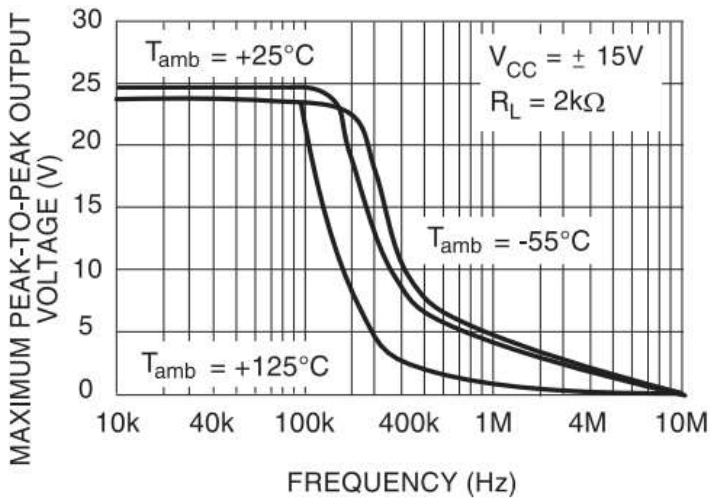
Low-noise JFET Quad Operational Amplifier
Typical Performance Characteristics.

 Figure 5. Maximum peak to peak output voltage vs frequency($R_L=2K\Omega$)

 Figure 6. Maximum peak to peak output voltage vs frequency($R_L=10K\Omega$)


Figure 7. Maximum peak to peak output voltage vs frequency and temperature

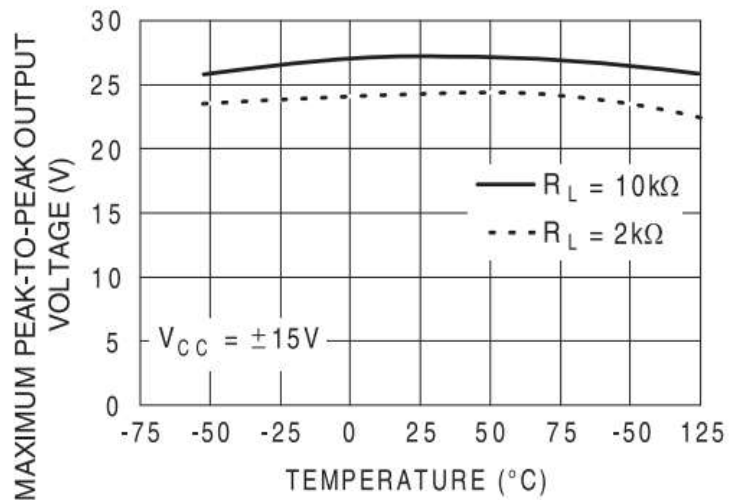


Figure 8. Maximum peak to peak output voltage vs free air temperature

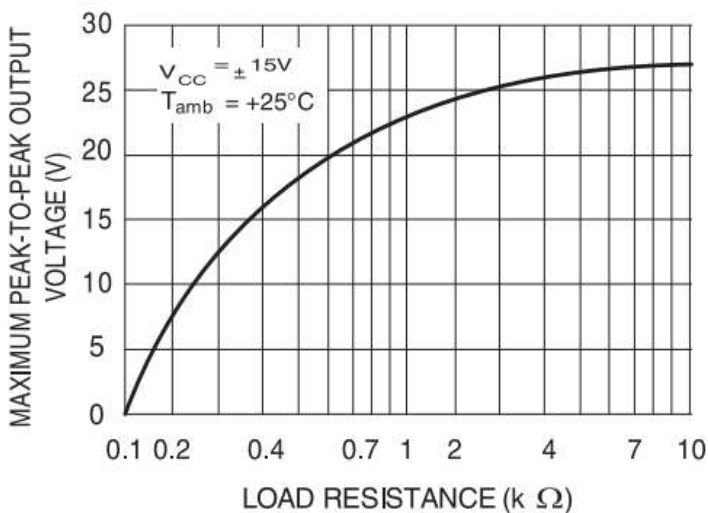


Figure 9. Maximum peak to peak output voltage vs load resistance

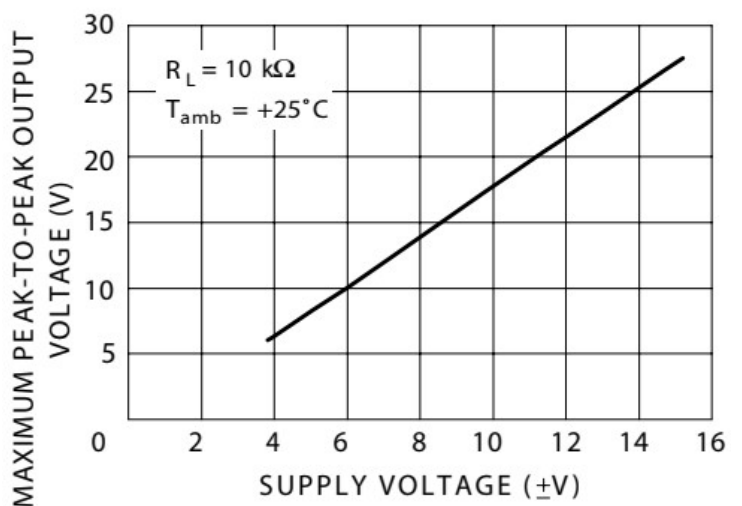


Figure 10. Maximum peak to peak output voltage vs supply voltage

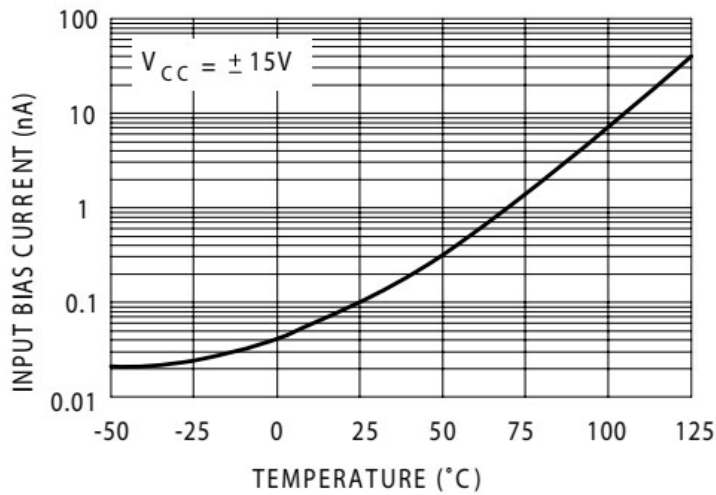
Low-noise JFET Quad Operational Amplifier
Typical Performance Characteristics(Con.)


Figure 11. Input bias current vs free air temperature

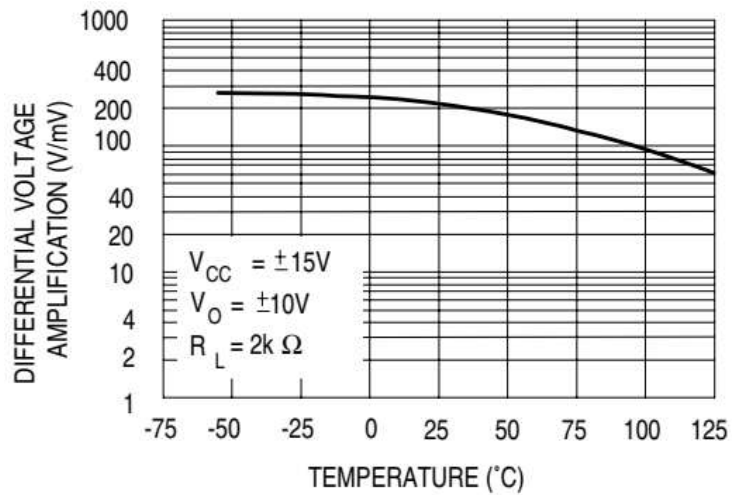


Figure 12. Large signal differential voltage amplification vs free air temperature

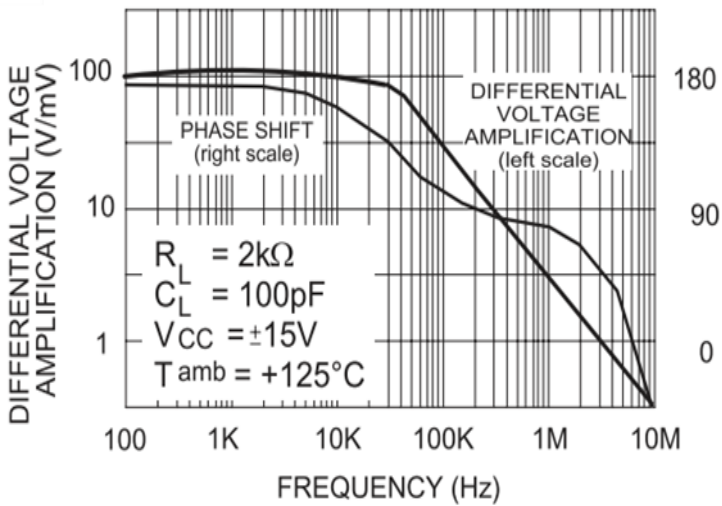


Figure 13. Large signal differential voltage amplification and phase shift vs frequency

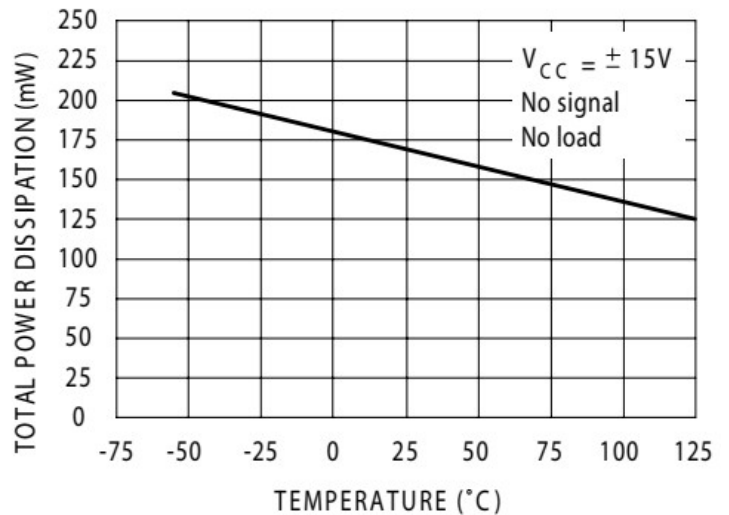


Figure 14. Total power dissipation vs free air temperature

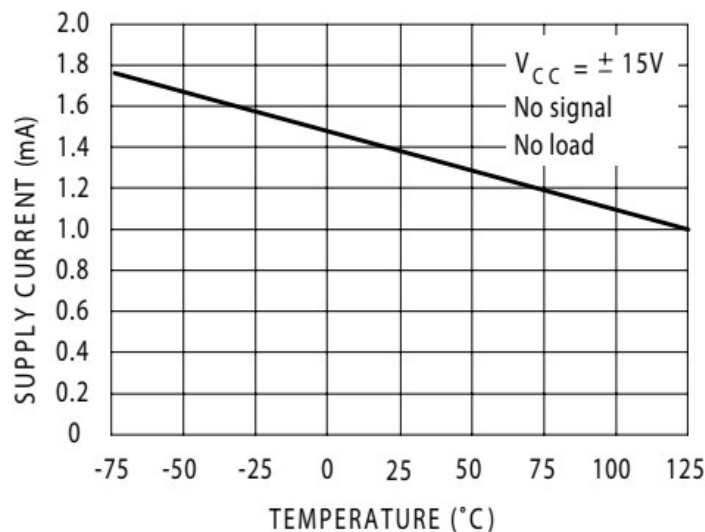


Figure 15. Supply current per amplifier vs free air temperature

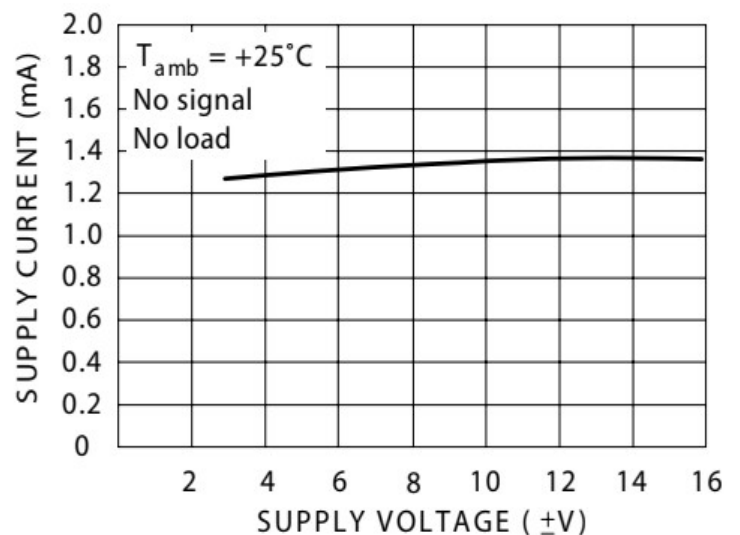


Figure 16. Common mode rejection ratio vs air temperature

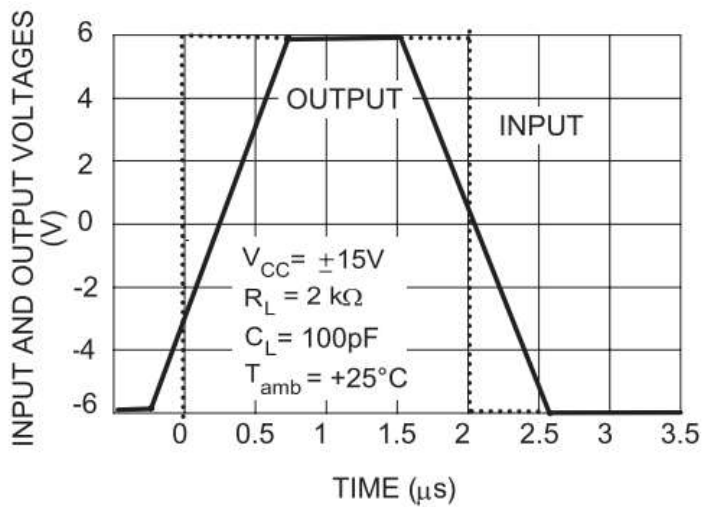
Low-noise JFET Quad Operational Amplifier
Typical Performance Characteristics(Con.)


Figure 17. Voltage follower large signal pulse response

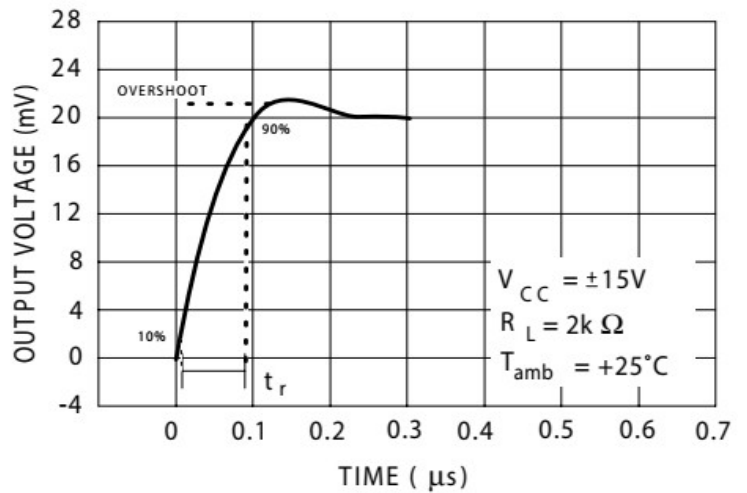


Figure 18. Output voltage vs elapsed time

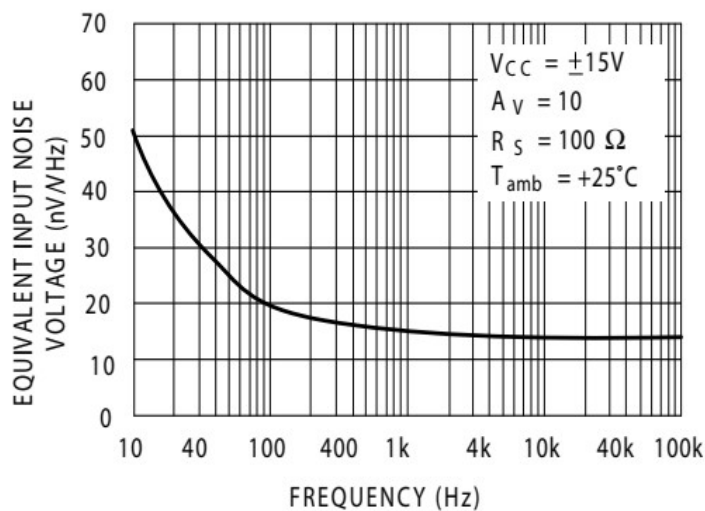


Figure 19. Equivalent input noise voltage vs frequency

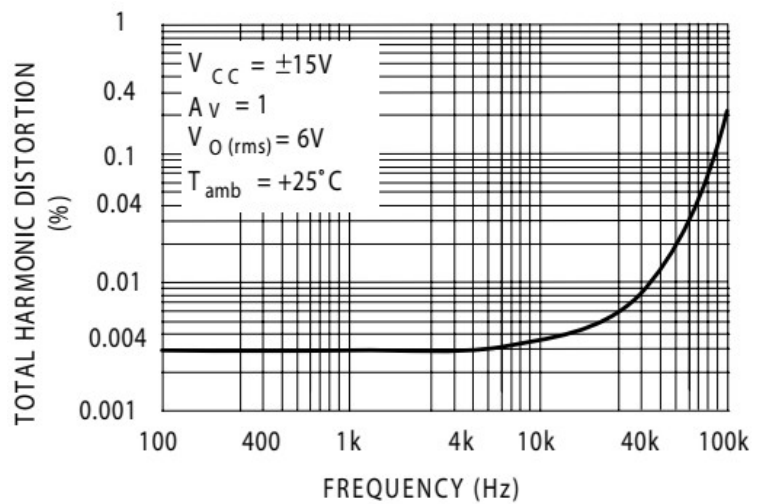


Figure 20. Total harmonic distortion vs frequency

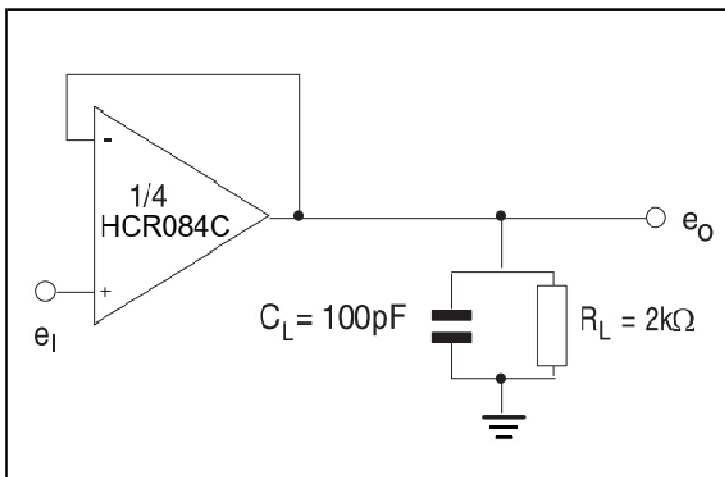
Parameter measurement information


Figure 21. Voltage Follower

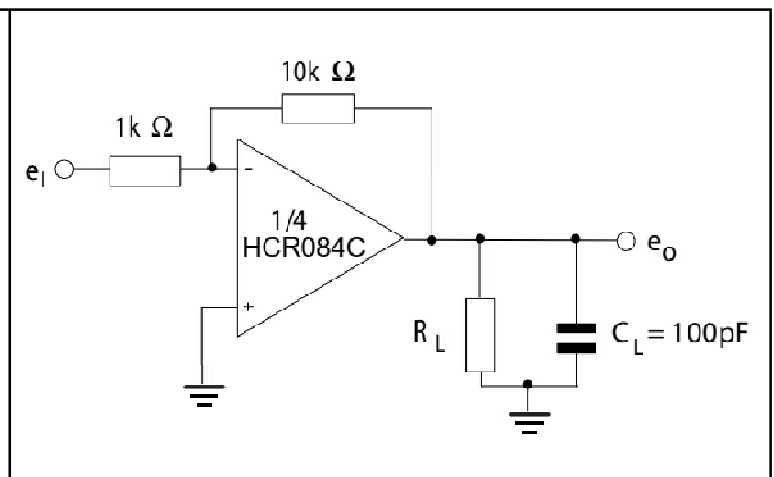


Figure 22. Gain-of-10 inverting amplifier

Low-noise JFET Quad Operational Amplifier

Typical Applications Circuit

Audio Distribution Amplifier

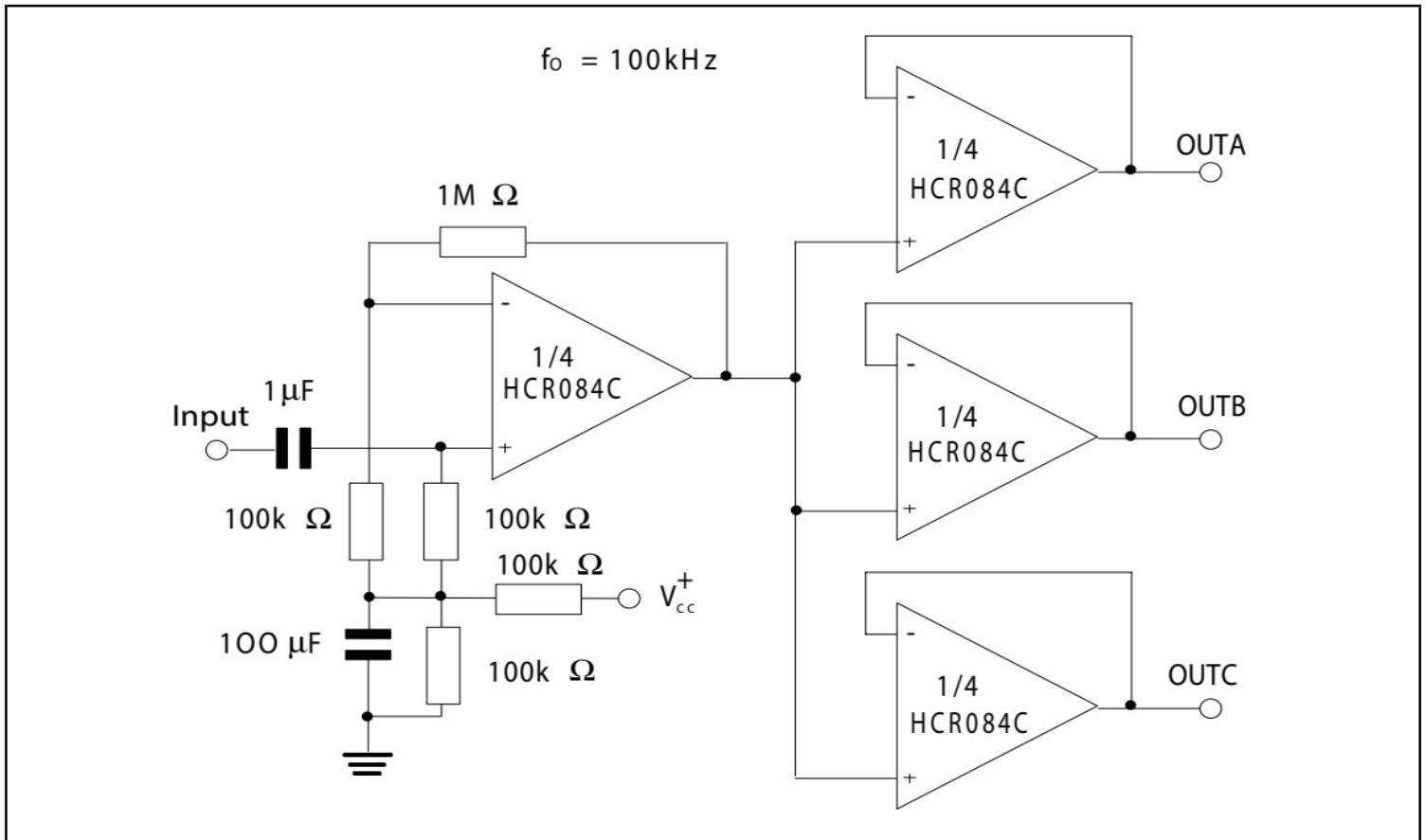


Figure 23. Audio Distribution Amplifier

Positive Feedback Bandpass Filter

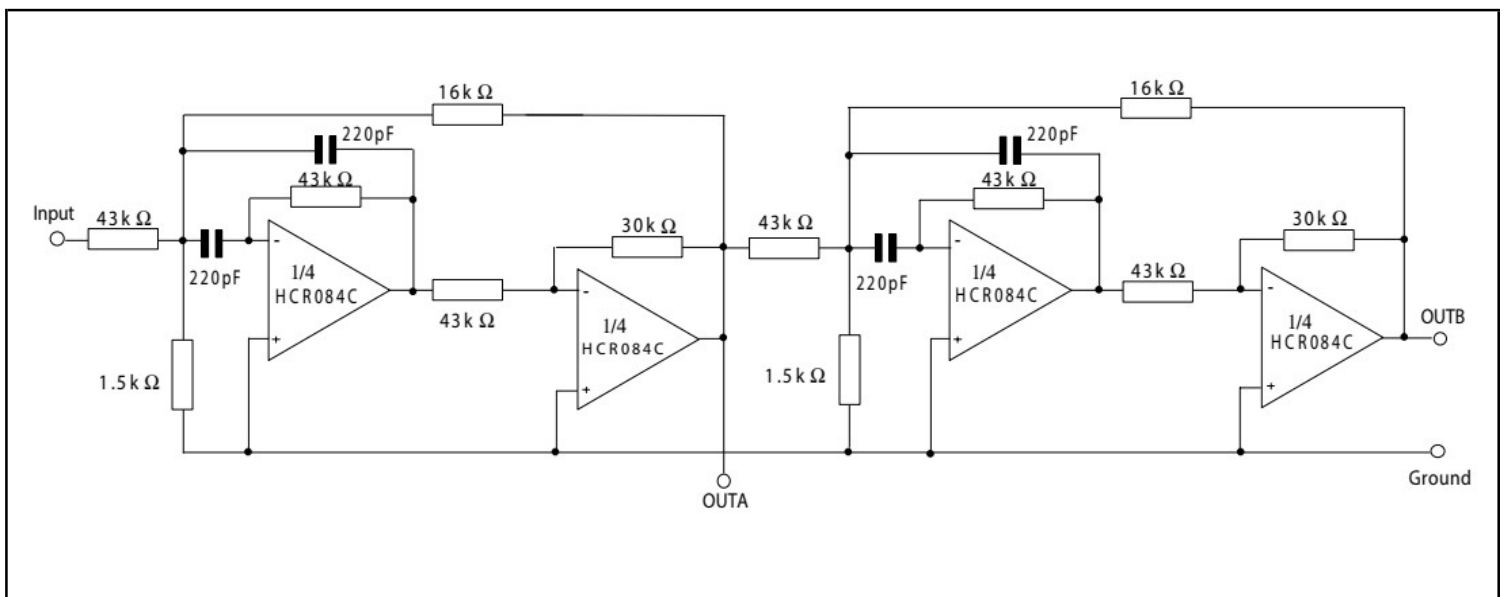
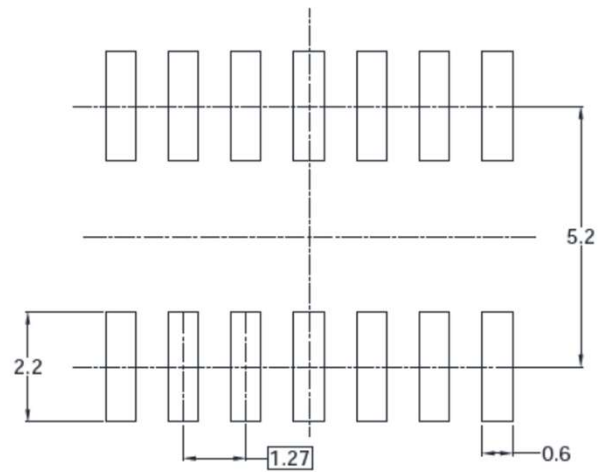
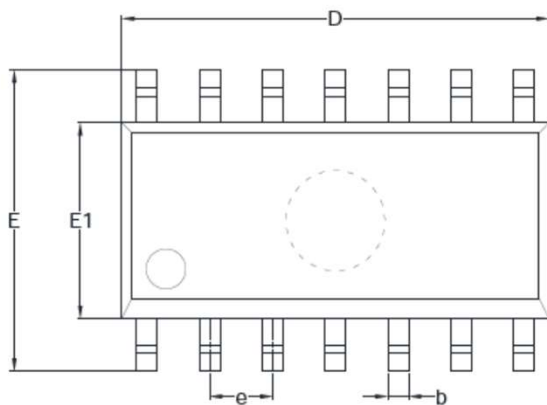
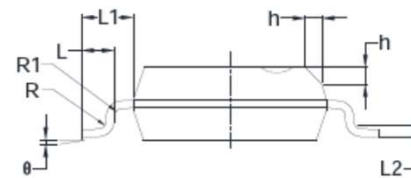
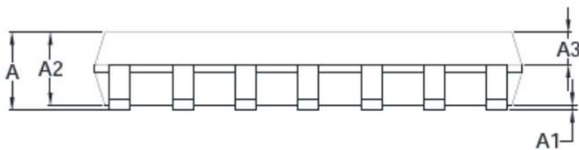


Figure 24. Positive Feedback Bandpass Filter

Low-noise JFET Quad Operational Amplifier
Mechanical Dimensions
M14: SOIC-14 Package

RECOMMENDED LAND PATTERN (Unit: mm)


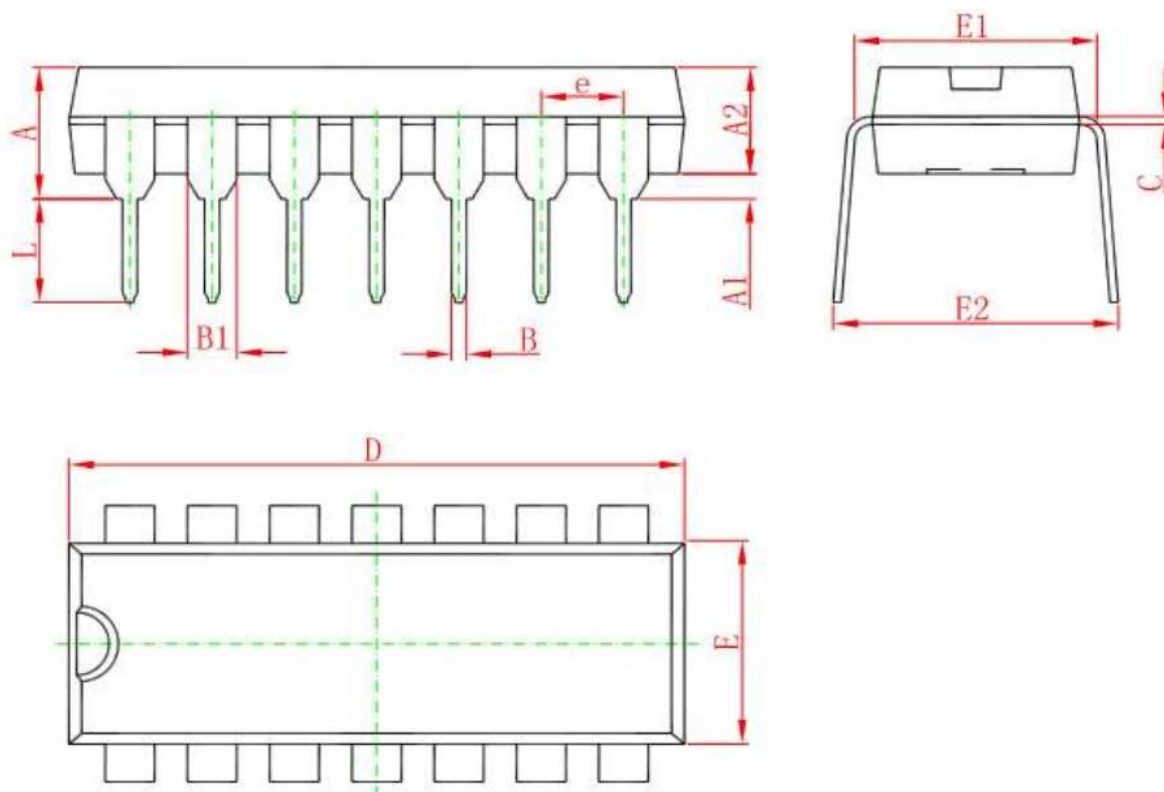
Symbol	Dimensions In Millimeters		Dimensions In Inches	
	MIN	MAX	MIN	MAX
A	1.35	1.75	0.053	0.069
A1	0.10	0.25	0.004	0.010
A2	1.25	1.65	0.049	0.065
A3	0.55	0.75	0.022	0.030
b	0.36	0.49	0.014	0.019
D	8.53	8.73	0.336	0.344
E	5.80	6.20	0.228	0.244
E1	3.80	4.00	0.150	0.157
e	1.27 BSC		0.050 BSC	
L	0.45	0.80	0.018	0.032
L1	1.04 REF		0.040 REF	
L2	0.25 BSC		0.01 BSC	
R	0.07		0.003	
R1	0.07		0.003	
h	0.30	0.50	0.012	0.020
θ	0°	8°	0°	8°

Low-noise JFET Quad Operational Amplifier

Mechanical Dimensions(Con.)

DP14: DIP-14 Package

Unit:mm

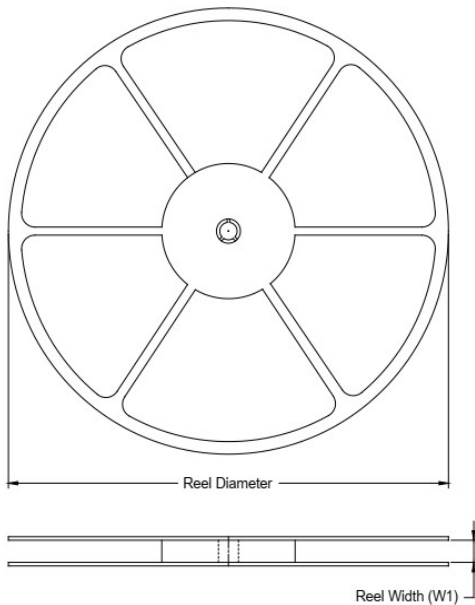


Symbol	Dimensions In Millimeters		Dimensions In Inches	
	Min	Max	Min	Max
A	3.710	4.310	0.146	0.170
A1	0.510		0.020	
A2	3.200	3.600	0.126	0.142
B	0.380	0.570	0.015	0.022
B1	1.524 (BSC)		0.060 (BSC)	
C	0.204	0.360	0.008	0.014
D	18.800	19.200	0.740	0.756
E	6.200	6.600	0.244	0.260
E1	7.320	7.920	0.288	0.312
e	2.540 (BSC)		0.100 (BSC)	
L	3.000	3.600	0.118	0.142
E2	8.400	9.000	0.331	0.354

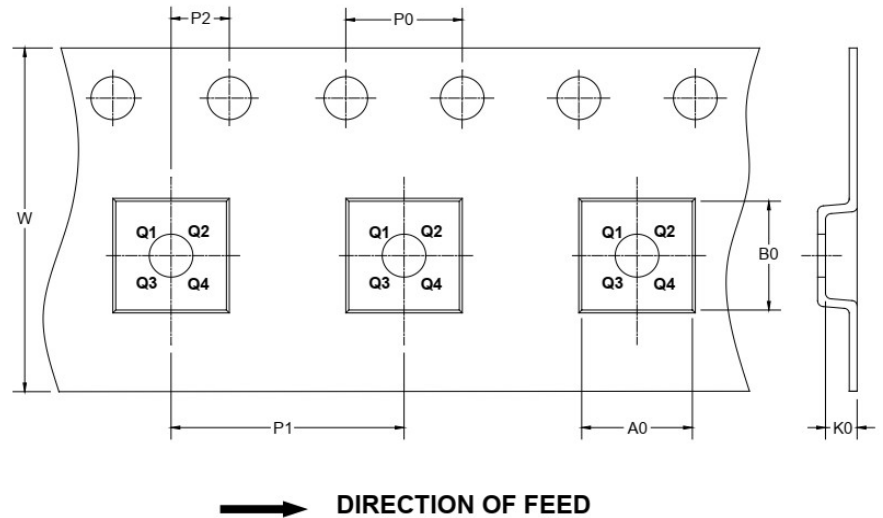
Low-noise JFET Quad Operational Amplifier

Tape and Reel Information

REEL DIMENSIONS



TAPE DIMENSIONS



NOTE: The picture is only for reference. Please make the object as the standard.

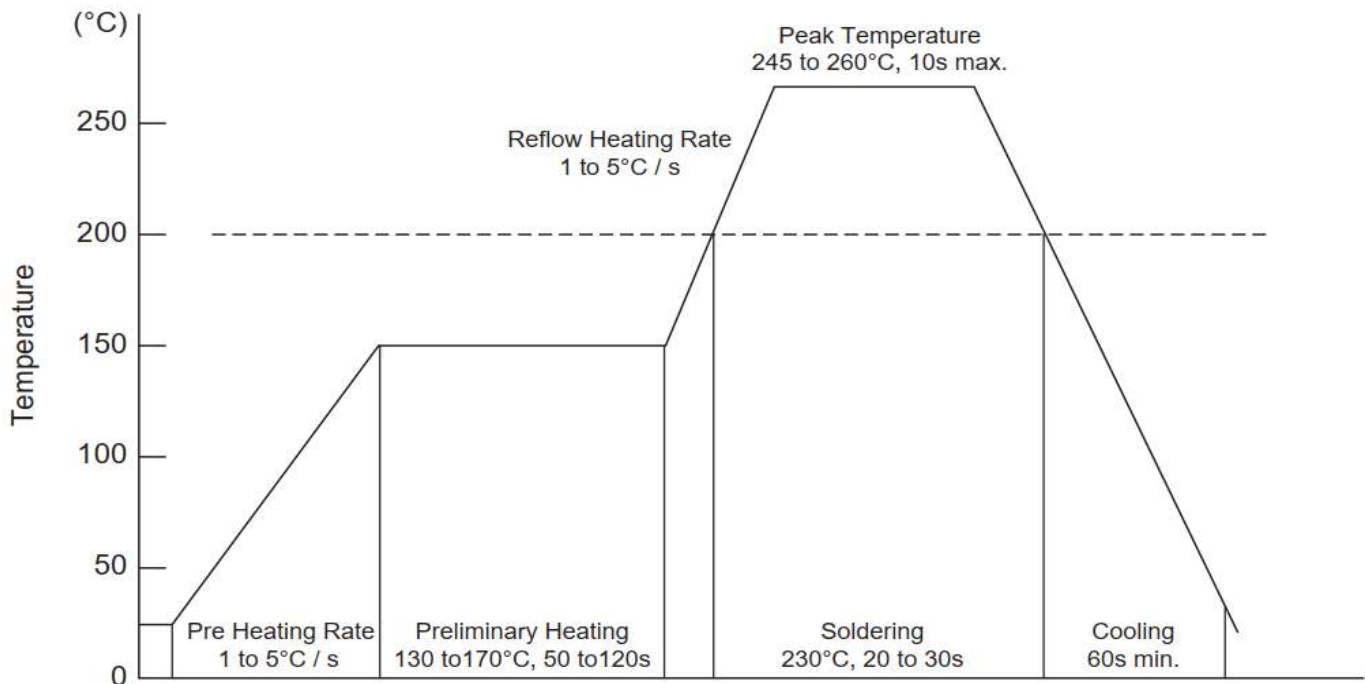
KEY PARAMETER LIST OF TAPE AND REEL

Package Type	Reel Diameter	Reel Width W1 (mm)	A0 (mm)	B0 (mm)	K0 (mm)	P0 (mm)	P1 (mm)	P2 (mm)	W (mm)	Pin1 Quadrant
SOIC-14	13"	12.4	6.40	5.40	2.10	4.0	8.0	2.0	12.0	Q1

Low-noise JFET Quad Operational Amplifier

Conditions of Soldering and Storage

- * Recommended condition of reflow soldering



Recommended peak temperature is over 245°C, if peak temperature is below 245°C, you may adjust the following parameters:

- * Time length of peak temperature (longer)
 - * Time length of soldering (longer)
 - * Thickness of solder paste (thicker)
- * Conditions of hand soldering
 - * Temperature : 300°C
 - * Time : 3s max
 - * Times : one time
 - * Storage conditions
 - * Temperature
5 to 40°C
 - * Humidity
30 to 80% RH
 - * Recommended period
One year after manufacturing